

17-24GHz Down Converter

GaAs Monolithic Microwave IC in SMD leadless package

Description

The CHR3364-QEG is a multifunction monolithic receiver, which integrates a balanced cold FET mixer, a LO chain with buffers associated to a time two multiplier, and a RF low noise amplifier including gain control.

It is designed for a wide range of applications, from military to commercial communication systems.

The circuit is manufactured with a pHEMT process, 0.25 μ m gate length, via holes through the substrate, air bridges and electron beam gate lithography.

It is supplied in RoHS compliant SMD package.

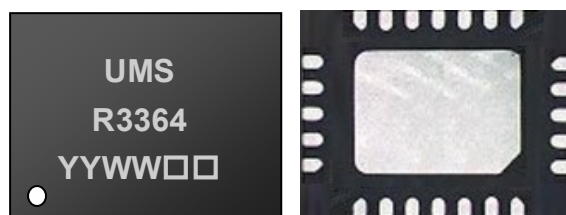

Main Features

- Broadband performances: 17-24GHz
- 11dB Conversion gain
- 17dBc Image Rejection
- 1dBm Input IP3
- 2.7dB Noise Figure for IF>0.1GHz
- 0dBm LO input Power
- DC bias: Vd=4V @ Id=320mA
- 24L-QFN4x5
- MSL3

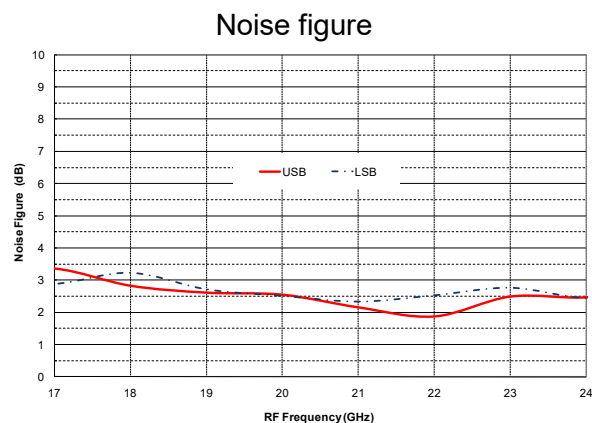

Main Electrical Characteristics

Tcase = +25°C

Symbol	Parameter	Min	Typ	Max	Unit
F _{RF}	RF frequency range	17.0		24.0	GHz
F _{LO}	LO frequency range	6.5		14.0	GHz
F _{IF}	IF frequency range	DC		3.5	GHz
C _G	Conversion gain		11.0		dB

Specifications

T_{case} = +25°C, V_d = +x.xV

Symbol	Parameter	Min	Typ	Max	Unit
F _{RF}	RF frequency range	17		24	GHz
F _{LO}	LO frequency range	6.5		14	GHz
F _{IF}	IF frequency range	DC		3.5	GHz
C _G	Conversion Gain		11		dB
NF	Noise Figure for IF>0.1GHz		2.7		dB
Im_rej	Image rejection ⁽¹⁾		17		dBc
P _{LO}	LO Input power		0		dBm
IIP3	Input IP3		1		dBm
2LO/RF	2LO leakage at RF port		-40		dBc
VD, VDL	DC drain voltage		4.0		V
ID	Drain current on VD pin for LO buffer		245		mA
IDL	Drain current on VDL pin for LNA		75		mA
VGL	LNA DC gate voltage ⁽²⁾		-0.5		V
VGM	Mixer DC gate voltage		-0.7		V

These values are representative of onboard measurements as defined on the drawing in paragraph "Evaluation mother board".

⁽¹⁾ An external combiner 90° is required on I / Q.

⁽²⁾ Typical VGL value for IDL = 75mA

See in paragraph "biasing option" other possibility to optimise differently the performances

Absolute Maximum Ratings ⁽¹⁾

T_{case} = +25°C

Symbol	Parameter	Values	Unit
VD, VDL	Drain bias voltage	5	V
ID+IDL	Drain bias current	430	mA
VGL	LNA Gate bias voltage	-2 to +0.4	V
VGM	Mixer Gate bias voltage	-2 to +0.4	V
P _{RF}	Maximum peak RF input power overdrive ⁽²⁾	+10	dBm
P _{LO}	Maximum peak LO input power overdrive ⁽²⁾	+10	dBm
T _j	Junction temperature ⁽³⁾	175	°C

⁽¹⁾ Operation of this device above anyone of these parameters may cause permanent damage.

⁽²⁾ Duration < 1s.

⁽³⁾ Thermal Resistance channel to ground paddle

Temperature Range

T _{case}	Operating temperature range	-40 to +95	°C
T _{stg}	Storage temperature range	-55 to +150	°C

Device thermal performance

All the figures given in this section are obtained assuming that the QFN device is only cooled down by conduction through the package thermal pad (no convection mode considered).

The temperature is monitored at the package back-side interface (Tcase).

The system maximum temperature must be adjusted in order to guarantee that Tjunction remains below the maximum value specified in the Absolute Maximum Ratings table.

So, the system PCB must be designed to comply with this requirement.

Parameter	Biasing conditions	Tjunction (°C)	R _{TH} (°C/W)	T50 (hours)
R _{TH} ⁽¹⁾ Thermal Resistance (Junction to Case)	Vd= 4V Id= 320mA P _{diss} = 1.28W	160	50.8	2.55E+7

¹ Assuming 95°C Tcase

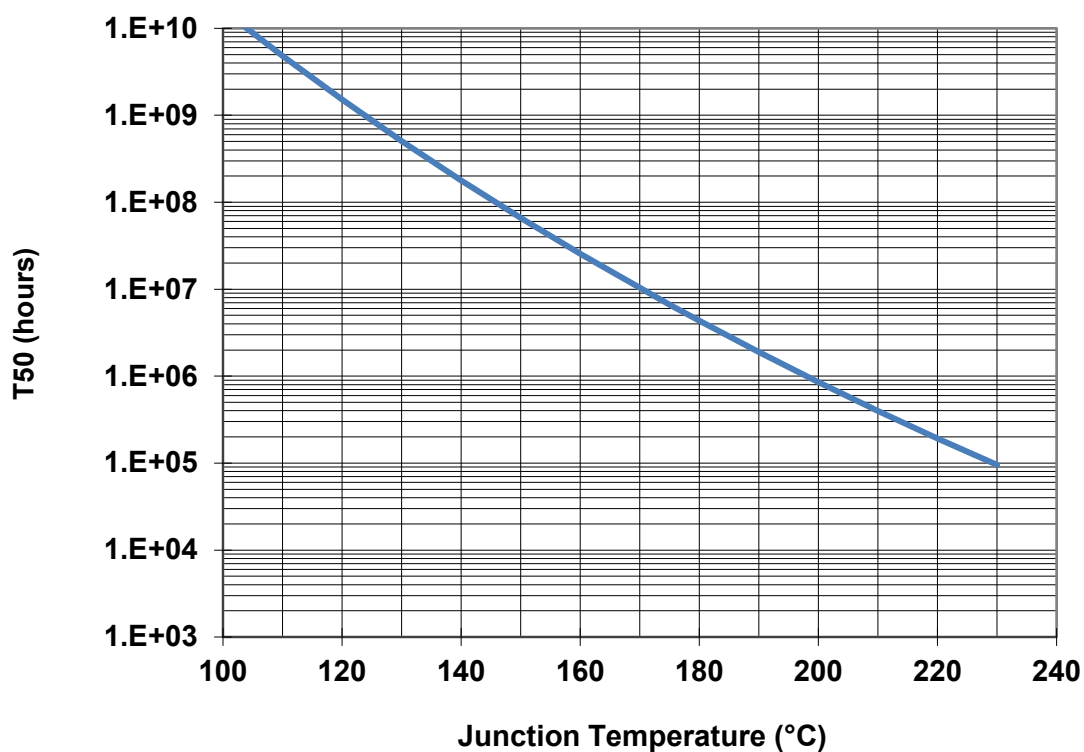

Typical Board Measurements

Tamb = +25°C, VD = VDL = 4.0V, VGL = -0.5V, VGM = -0.7V, P_{LO} = 0dBm

The values shown on the following pages are representative of on-board measurements where results are given on package access planes.

Noise Figure in Supradyne and Infradyne Mode versus RF Frequency

$$F_{RF} = 2xF_{LO} \pm F_{IF}, F_{IF} = 2.0\text{GHz}$$

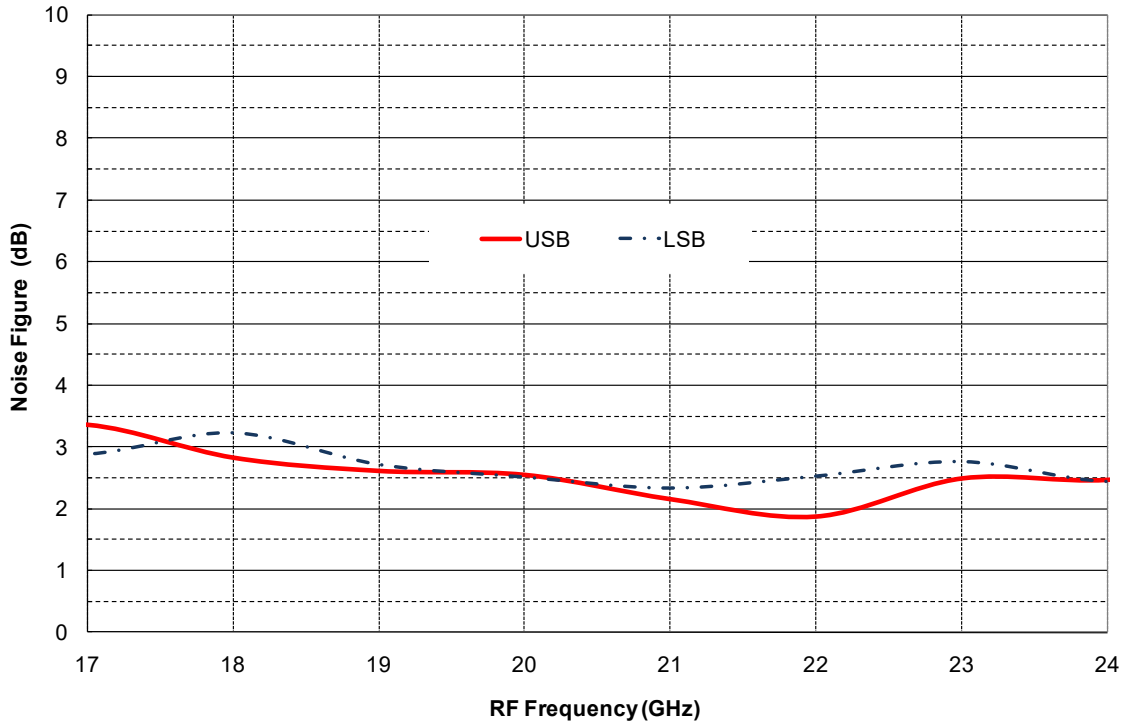

Typical Board Measurements

Tamb = +25°C, VD = VDL = 4.0V, VGL = -0.5V, VGM = -0.7V, PLo = 0dBm

Conversion Gain in Supradynne and Infradyne Mode versus RF Frequency
 $F_{RF} = 2xF_{LO} \pm F_{IF}$, $F_{IF} = 3.5\text{GHz}$

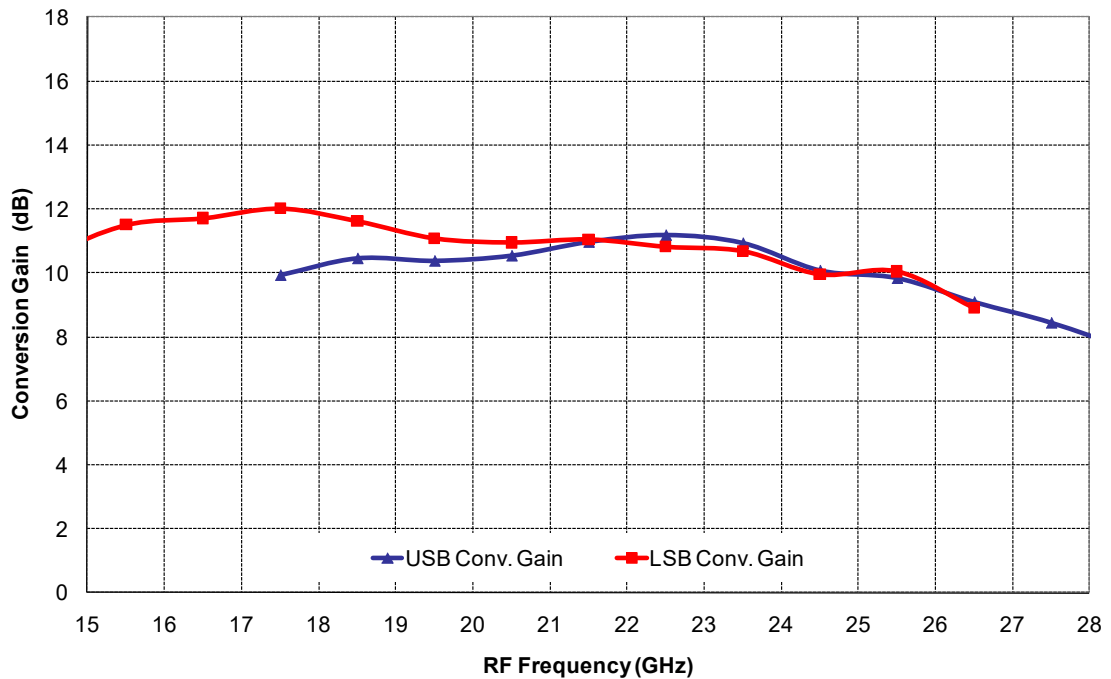
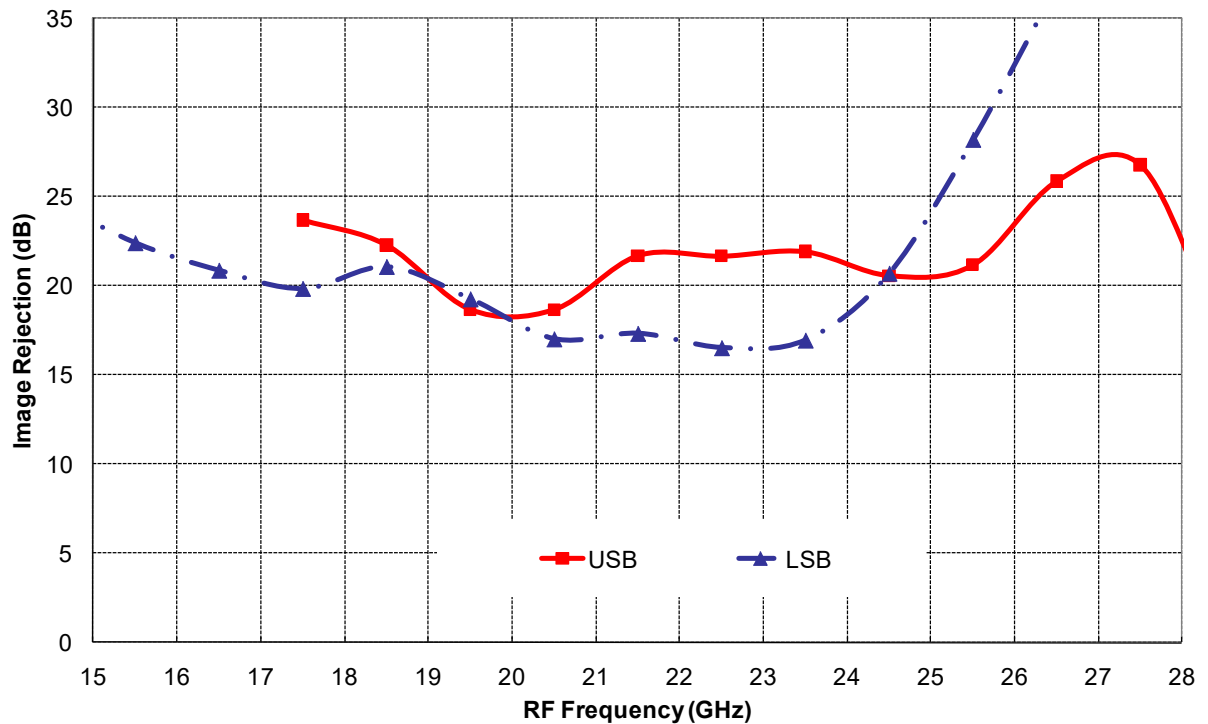

Image Rejection versus RF Frequency
 $F_{RF} = 2xF_{LO} \pm F_{IF}$, $F_{IF} = 3.5\text{GHz}$



Typical Board Measurements

Tamb = +25°C, VD = VDL = 4.0V, VGL = -0.5V, VGM = -0.7V, P_{LO} = 0dBm

Input IP3 in Supradyne Mode versus RF Frequency

$$F_{RF} = 2xF_{LO} + F_{IF}, F_{IF} = 3.5\text{GHz}$$

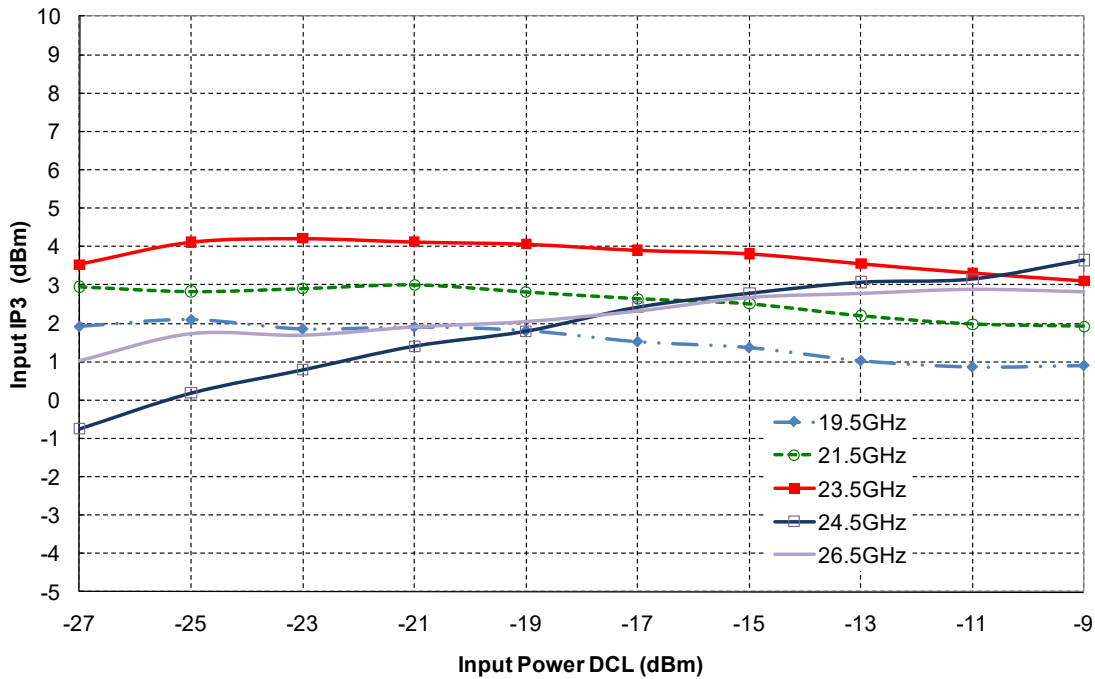

Input IP3 in Infradyne Mode versus RF Frequency

$$F_{RF} = 2xF_{LO} - F_{IF}, F_{IF} = 3.5\text{GHz}$$

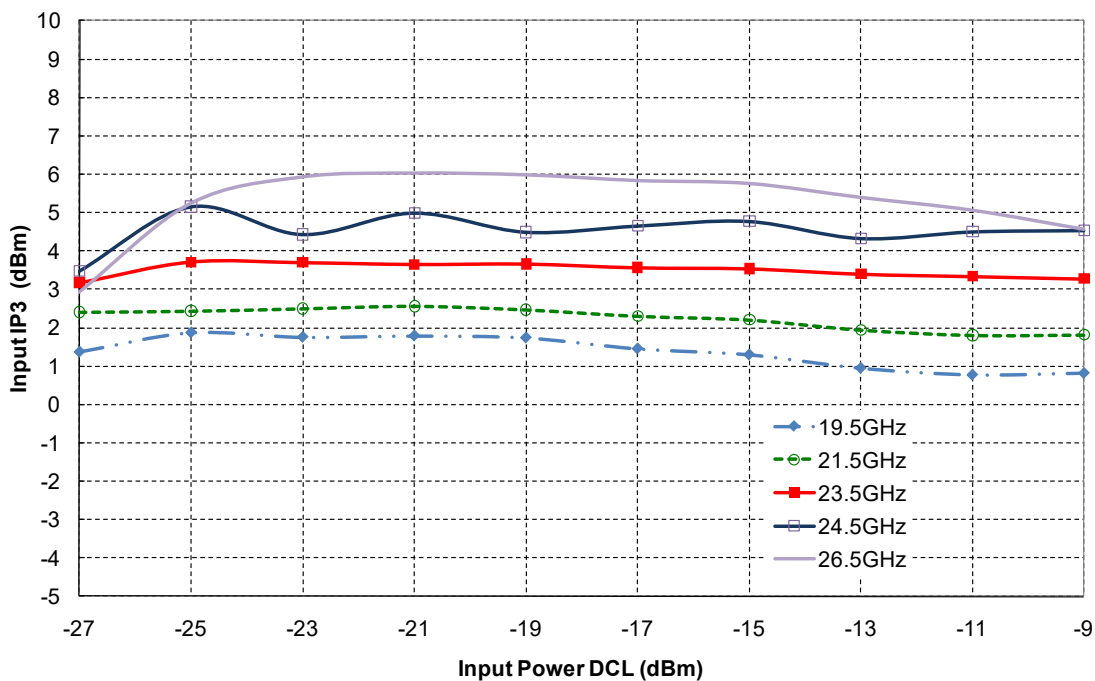

Typical Board Measurements

Tamb = +25°C, VD = VDL = 4.0V, VGL = -0.5V, VGM = -0.7V, PLo = 0dBm

IMD3 in Supradyne Mode versus RF Frequency

$$F_{RF} = 2 \times F_{LO} + F_{IF}, F_{IF} = 3.5\text{GHz}$$

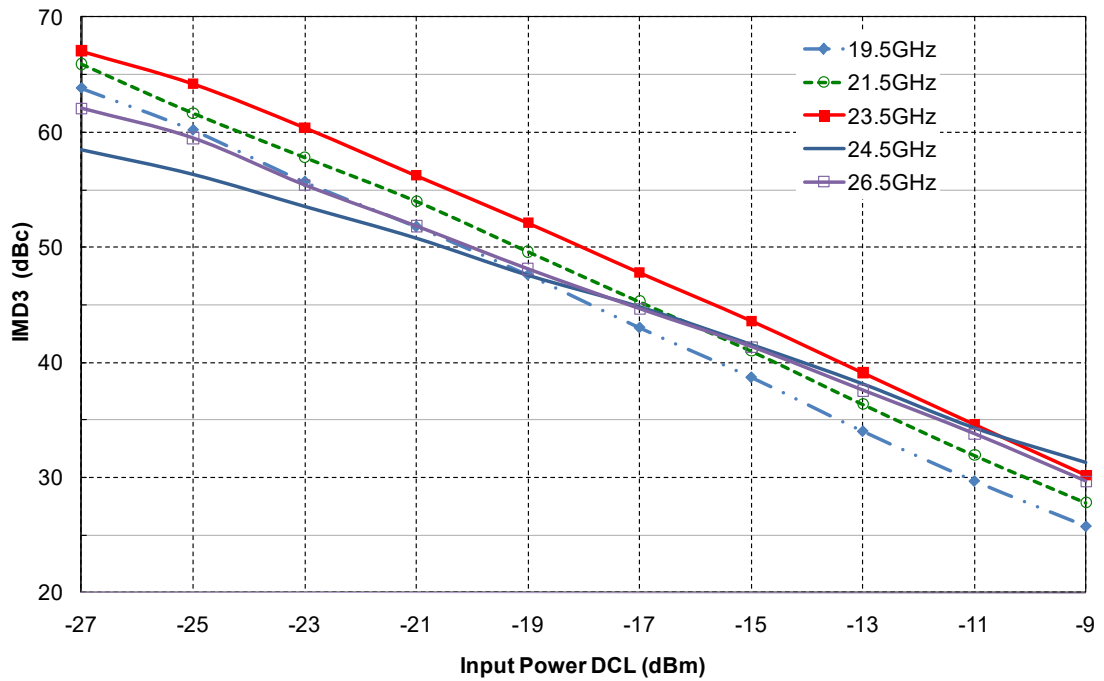

LO & RF return loss versus frequency

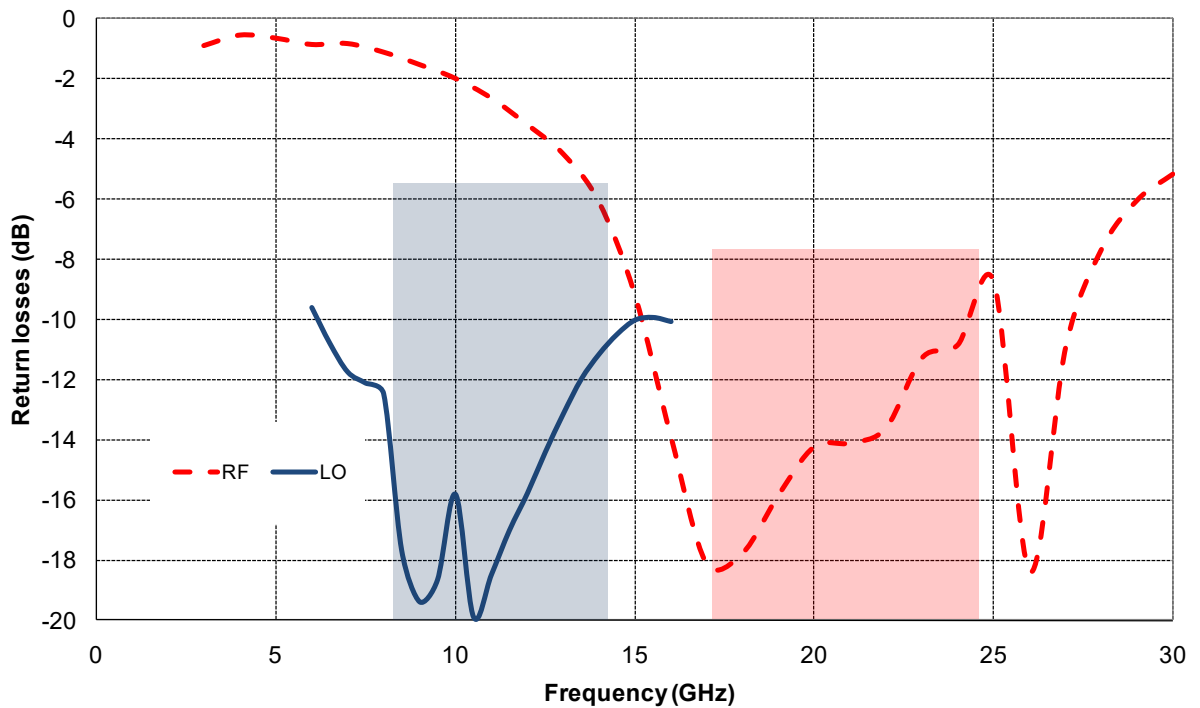

Temperature Board Measurements

T = [-40, +25, +85] °C, VD = VDL = 4.0V, VGL = -0.5V, VGM = -0.7V, P_{LO} = 0dBm

Conversion Gain in Supradyn Mode versus RF Frequency

$$F_{RF} = 2xF_{LO} + F_{IF}, F_{IF} = 3.5\text{GHz}$$

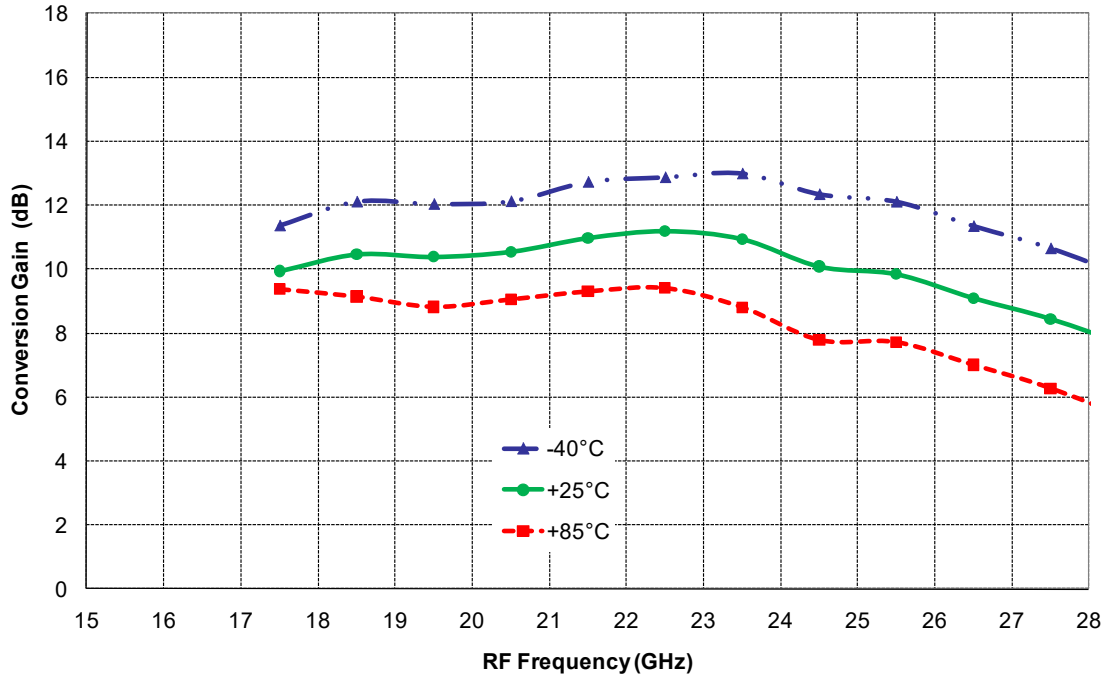

Conversion Gain in Infradyne Mode versus RF Frequency

$$F_{RF} = 2xF_{LO} - F_{IF}, F_{IF} = 3.5\text{GHz}$$

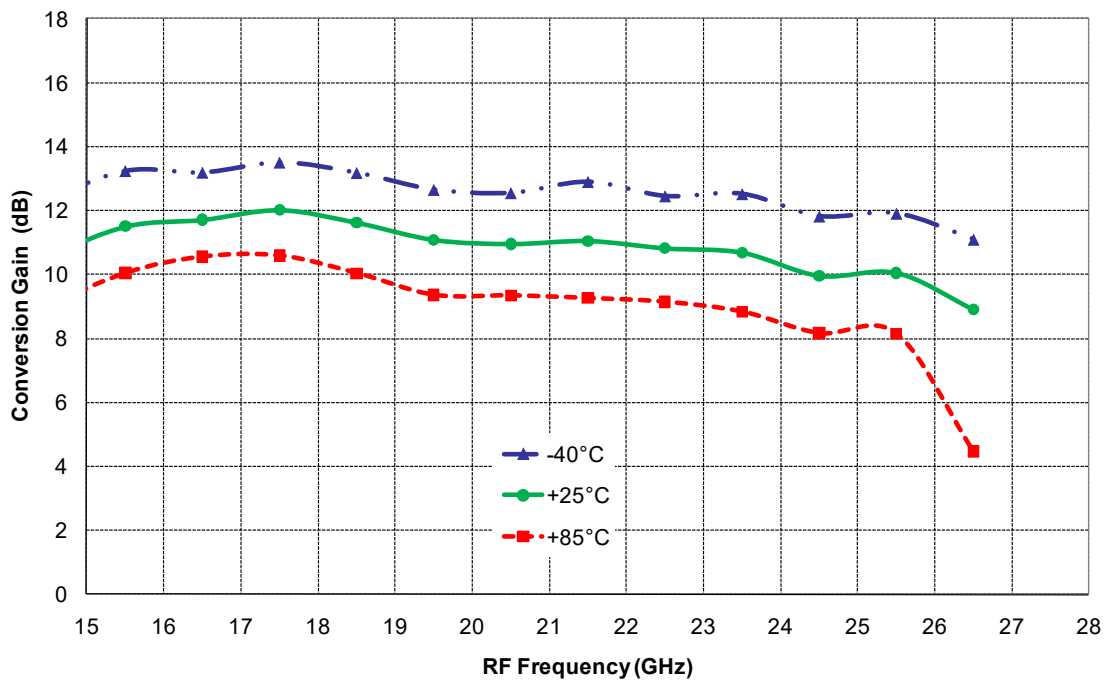

Temperature Board Measurements

T = [-40, +25, +85] °C, VD = VDL = 4.0V, VGL = -0.5V, VGM = -0.7V, P_{LO} = 0dBm

Input IP3 in Supradyne Mode versus RF Frequency

$$F_{RF} = 2xF_{LO} + F_{IF}, F_{IF} = 3.5\text{GHz}$$

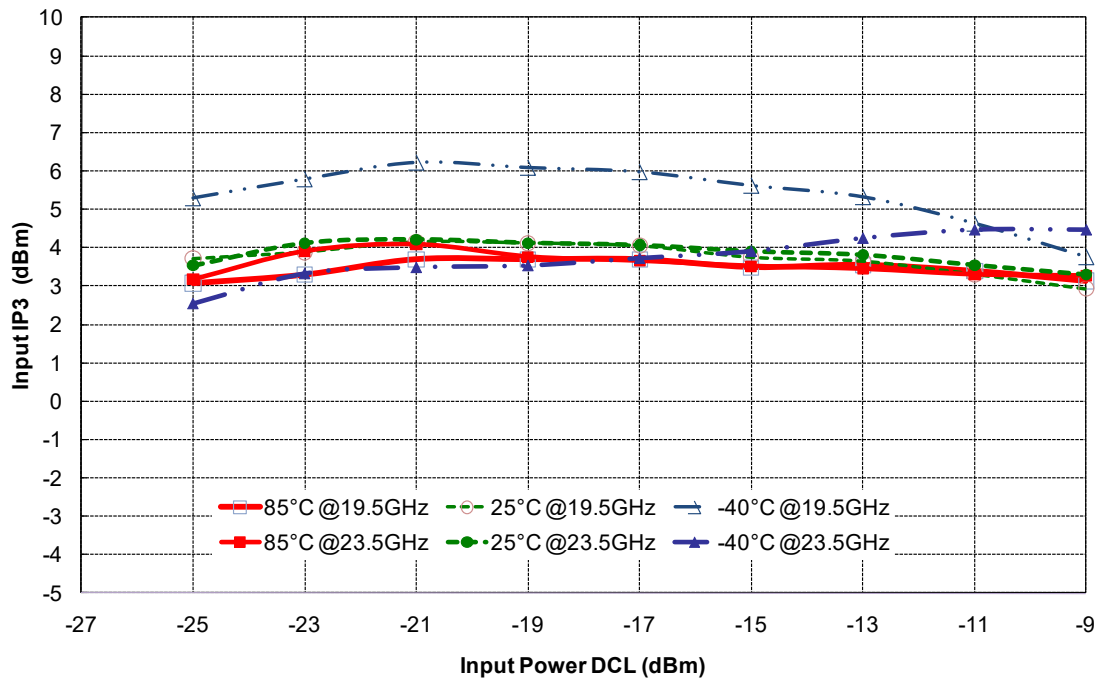

Package outline ⁽¹⁾ ⁽²⁾

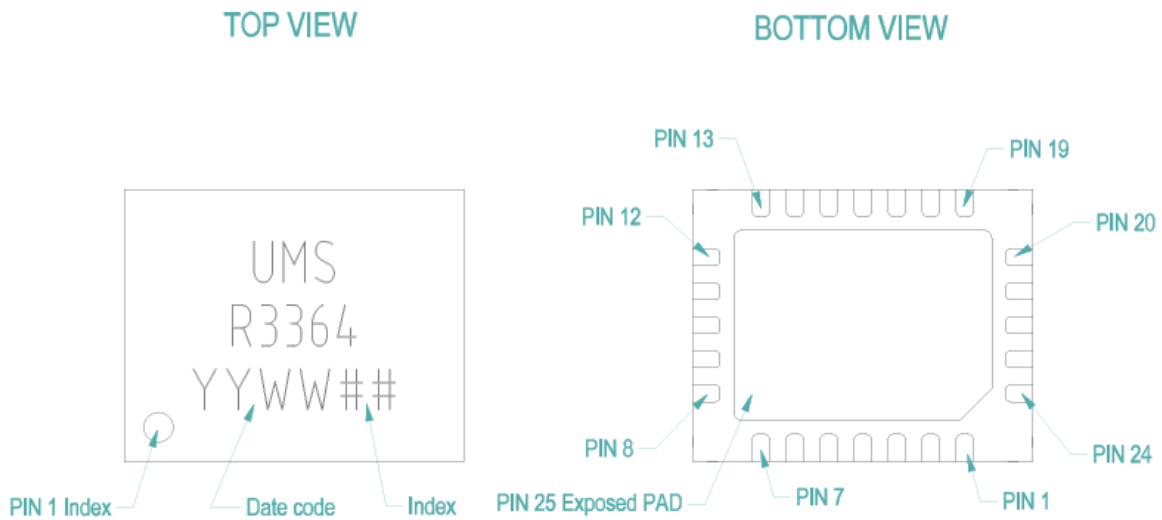

PACKAGE OUTLINE QEG03

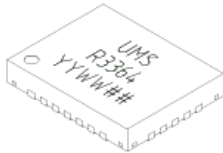

1- Nc	8- Nc	15- LO	22- Q
2- Nc	9- VGL	16- GND	23- Nc
3- Nc	10- VDL	17- Nc	24- Nc
4- GND	11- VGM	18- Nc	25- GND
5- RF	12- VD	19- Nc	
6- GND	13- Nc	20- I	
7- Nc	14- GND	21- GND	

⁽¹⁾ Refer to the application note AN0017 (<https://www.ums-rf.com>) for general consideration and recommendations for Molded Plastic QFN/DFN packages.

⁽²⁾ It is strongly recommended to ground all pins marked “Gnd” through the PCB board. Ensure that the PCB board is designed to provide the best possible ground to the package.

Evaluation mother board

- Compatible with the proposed footprint.
- Based on typically Ro4003 / 8mils or equivalent.
- Using a micro-strip to coplanar transition to access the package.
- Recommended for the implementation of this product on a module board.
- Decoupling capacitors of 10nF \pm 10% are recommended for all DC accesses.
- See application note AN0017 for details.

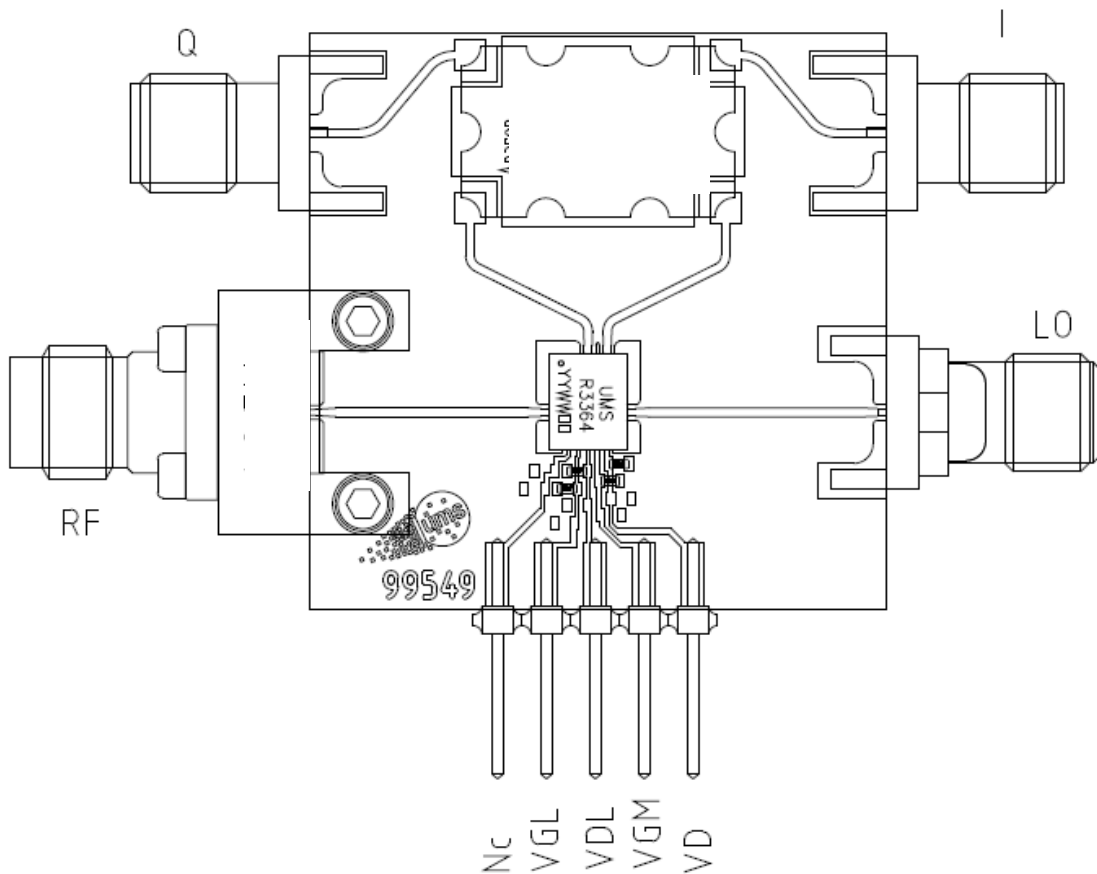

Hybrid coupler 90° 2-4GHz

Notes

Due to ESD protection circuits on RF and LO input, an external capacitance might be requested to isolate the product from external voltage that could be present on these accesses.

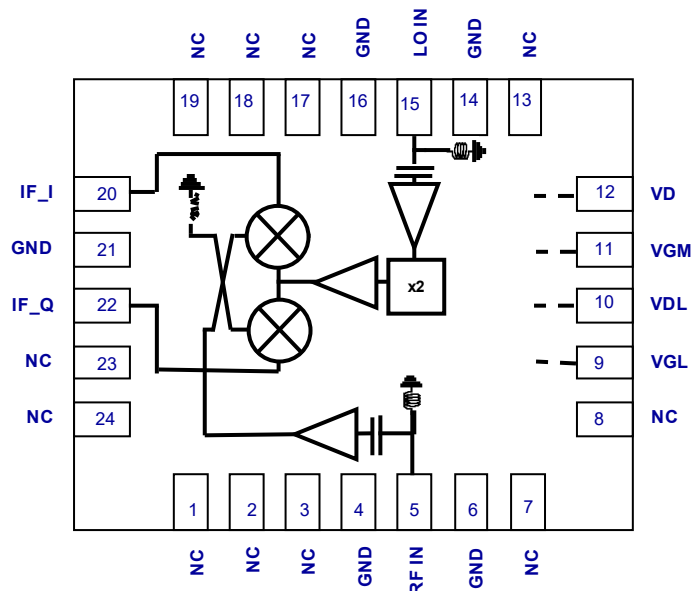

ESD protections are also implemented on gate accesses.

The DC connections do not include any decoupling capacitor in package, therefore it is mandatory to provide a good external DC decoupling (10nF) on the PC board, as close as possible to the package.

Biasing Options

In order to improve the conversion gain or the input IP3, the biasing could be tuned. VGL voltage allows controlling IDL current.

Table below gives the typical value for main characteristics

	VD=VDL= 4.0V IDL= 75mA	VD=VDL= 4.5V IDL= 110mA
Conversion Gain (dB)	11	12.5
Noise Figure (dB)	2.7	2.6
Input IP3 (dBm)	+1	+3
VGL (V)	-0.5	-0.4
ID (mA)	245	250
ID +IDL (mA)	320	360
Total DC power consumption (mW)	1280	1620

DC Schematic

LNA: 4V, 75mA

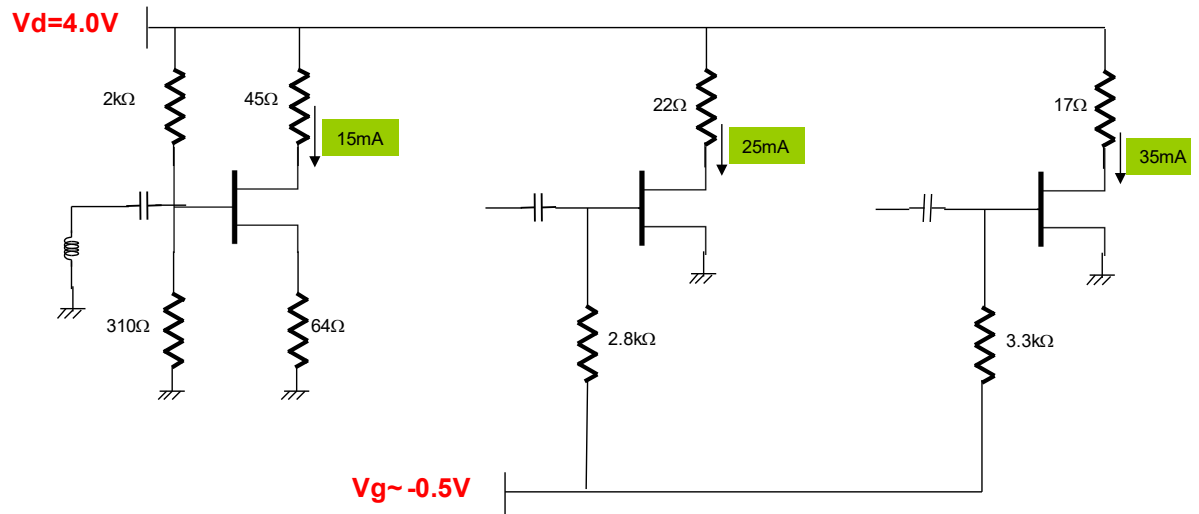

LO Buffer: 4V, 245mA

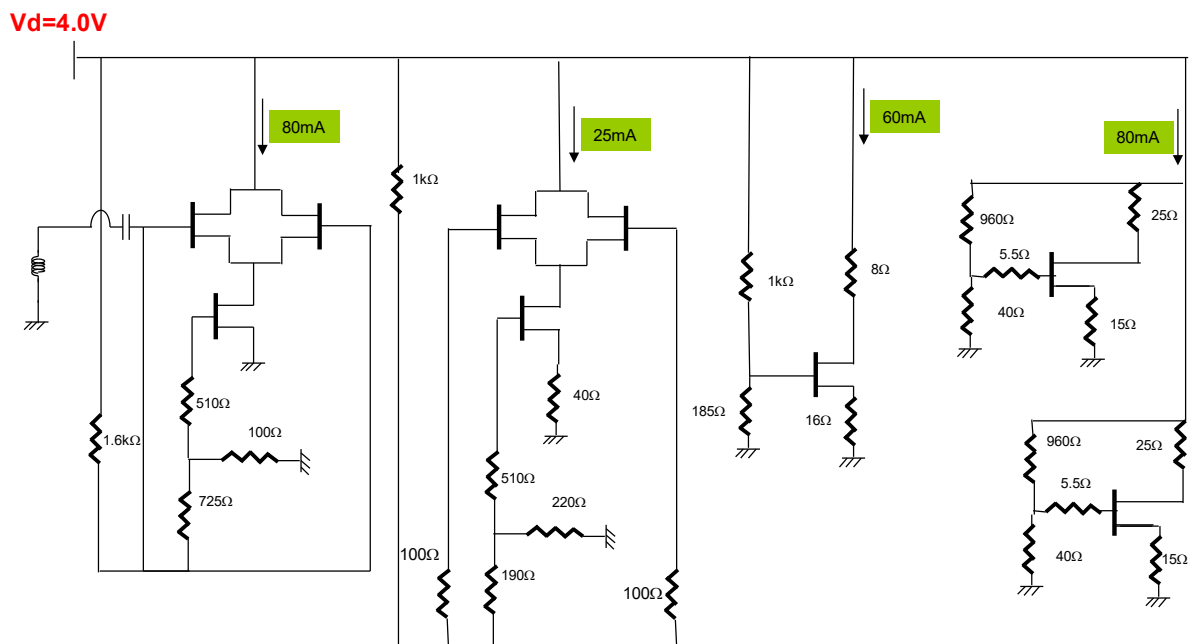

Recommended package footprint

Refer to the application note AN0017 available at <https://www.ums-rf.com> for package footprint recommendations.

SMD mounting procedure

For the mounting process standard techniques involving solder paste and a suitable reflow process can be used. For further details, see application note AN0017 at <https://www.ums-rf.com>.

Recommended environmental management

UMS products are compliant with the regulation in particular with the directives RoHS N°2011/65 and REACH N°1907/2006. More environmental data are available in the application note AN0019 also available at <https://www.ums-rf.com>.

Recommended ESD management

Refer to the application note AN0020 available at <https://www.ums-rf.com> for ESD sensitivity and handling recommendations for the UMS package products.

Ordering Information

QFN 4x4 package:

CHR3364-QEG/XY

Stick: XY = 20

Tape & reel: XY = 21

Information furnished is believed to be accurate and reliable. However **United Monolithic Semiconductors S.A.S.** assumes no responsibility for the consequences of use of such information nor for any infringement of patents or other rights of third parties which may result from its use. No license is granted by implication or otherwise under any patent or patent rights of **United Monolithic Semiconductors S.A.S.**. Specifications mentioned in this publication are subject to change without notice. This publication supersedes and replaces all information previously supplied. **United Monolithic Semiconductors S.A.S.** products are not authorised for use as critical components in life support devices or systems without express written approval from **United Monolithic Semiconductors S.A.S.**