

37- 40GHz Power Amplifier

GaAs Monolithic Microwave IC in SMD leadless package

Description

The CHA6194-QXG is a four stage monolithic GaAs high power circuit producing 1.2 Watt output power. It is highly linear with possible gain control and integrates a power detector. ESD protections are included.

It is designed for Point To Point Radio or MIMO antenna applications.

The circuit is manufactured with a pHEMT process, 0.15 μ m gate length.

It is supplied in RoHS compliant SMD package.

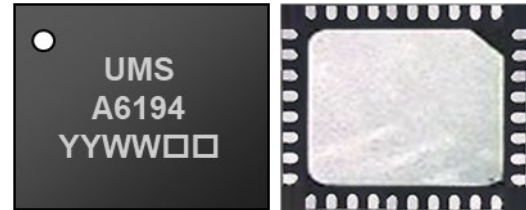

36 lead 6x5 mm QFN package

Main Features

- Broadband performances: 37-40GHz
- 31dBm saturated power
- 38dBm OIP3
- 20dB gain
- DC bias: $V_d = 6V @ I_d = 0.8A$
- QFN 6x5
- MSL3

Output power vs frequency

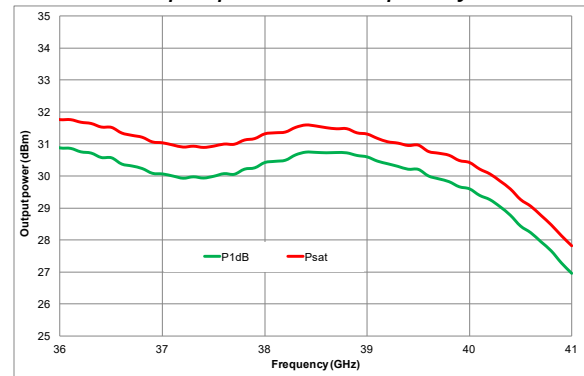

Main Electrical Characteristics

Tcase = +25°C

Symbol	Parameter	Min	Typ	Max	Unit
Freq	Frequency range	37		40	GHz
Gain	Linear Gain	18	20	23	dB
Psat	Saturated output power	30	31		dBm
OIP3	Output IP3	36.5	38		dBm

Electrical CharacteristicsT_{case} = +25°C, V_d = +6.0V

Symbol	Parameter	Min	Typ	Max	Unit
Fop	Operating frequency range	37		40	GHz
Gain	Small Signal Gain	18	20	23	dB
ΔG	Gain variation in temperature		± 0.04		dB/°C
Psat	Saturated Output Power	30	31		dBm
P1dB	Output power at 1dB compression	29	30		dBm
OIP3	Output IP3	36.5	38		dBm
PAE	PAE at saturation		18		%
CG	Gain regulation range		15		dB
R _{lin}	Input Return Loss		13		dB
R _{lout}	Output Return Loss		13		dB
Dr	Detection dynamic range(for output power detection up to Psat)		32		dB
V _{detect}	Voltage detection V _{REF} - V _{DET} up to Psat		5 to 2500		mV
V _g	DC gate Voltage		-0.65		V
I _{dq}	Total drain current		0.8		A

These values are representative of onboard measurements as defined on the drawing in paragraph "Evaluation mother board".

“Power ON” sequence

1. Ground the device
2. All DC supplies are set to 0V
3. Tune the gate from 0V to -2V with step 0.
4. Tune the drain access from 0V to +6V, step 0.5V
5. Slowly increase the gate voltage by 0.1V step while monitoring the drain current, and set the gate voltage value to get the nominal drain current consumption without RF signal (800mA)
6. Apply RF signal

“Power OFF” sequence

1. Turn off RF signal
2. Slowly decrease the drain voltage from 6V to 0V, step 0.5V
3. Set up the gate voltage from nominal value to 0V step 0.1V
4. Unplug the component

Absolute Maximum Ratings ⁽¹⁾

Symbol	Parameter	Values	Unit
Vd	DC Drain bias voltage without RF ⁽²⁾	8	V
Id	Drain bias quiescent current ⁽²⁾	1000	mA
Vg	Gate bias voltage@ ⁽²⁾	-2 to 0	V
Pin	Maximum Input Power ⁽²⁾	+15	dBm

⁽¹⁾ Operation of this device above anyone of these parameters may cause permanent damage.

⁽²⁾ For an operating temperature of 25°C

Temperature range

Symbol	Parameter	Values	Unit
Ta	Operating temperature range	-40 to +95	°C
Tstg	Storage temperature	-55 to +150	°C

Typical Bias Conditions

Tcase = +25°C

Symbol	Pad N°	Parameter	Values	Unit
Vd1	7	DC Drain voltage 1 st stage	6.0	V
Vd2	6	DC Drain voltage 2 nd stage	6.0	V
Vd3	4, 23	DC Drain voltage 3 rd stage	6.0	V
Vd4	2, 25	DC Drain voltage 4 th stage	6.0	V
Vg1	19	DC Gate voltage 1 st stage	-0.65	V
Vg2	21	DC Gate voltage 2 nd stage	-0.65	V
Vg3	5, 22	DC Gate voltage 3 rd stage	-0.65	V
Vg4	3, 24	DC Gate voltage 4 th stage	-0.65	V

Device thermal performance

All the figures given in this section are obtained assuming that the QFN device is only cooled down by conduction through the package thermal pad (no convection mode considered).

The temperature is monitored at the package back-side interface (Tcase).

The system maximum temperature must be adjusted in order to guarantee that Tjunction remains below the maximum value specified in the Absolute Maximum Ratings table.

So, the system PCB must be designed to comply with this requirement.

Parameter	Biasing conditions	Tjunction (°C)	RTH (°C/W)	T50 (hours)
RTH ⁽¹⁾ Thermal Resistance (Junction to Case)	Vd= 6V Id= 1300mA Pdiss= 6.25W	206	19.36	1.8E+06

⁽¹⁾ Assuming 85°C Tcase

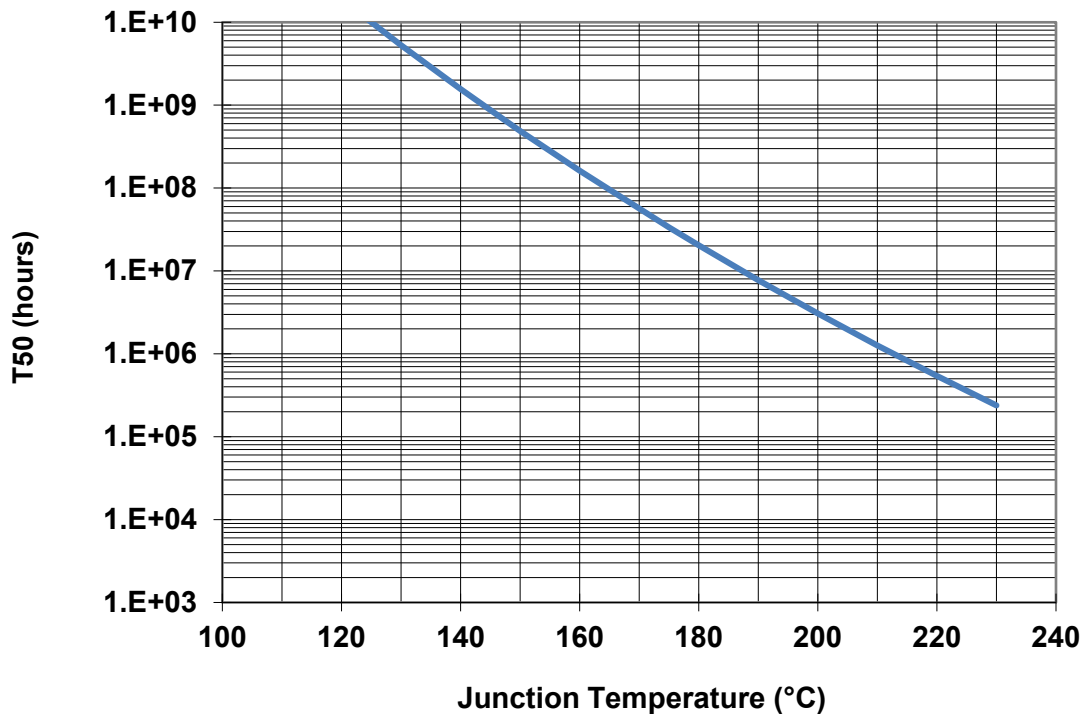

Typical Package Sij parameters

Tcase = +25°C, Vd = +6.0V, Id = 800mA

Freq (GHz)	S11 (dB)	PhS11 (°)	S21 (dB)	PhS21 (°)	S12 (dB)	PhS12 (°)	S22 (dB)	PhS22 (°)
5	-0.848	58.7	-78.174	-64.7	-69.773	6.1	-0.458	77.4
6	-1.122	22.5	-58.913	161.6	-76.522	-115.1	-0.635	52.3
7	-1.727	-27.6	-45.260	113.9	-72.227	88.0	-0.957	23.7
8	-2.305	-97.5	-34.505	50.1	-66.501	39.4	-1.613	-11.9
9	-2.017	-169.5	-23.834	-27.3	-60.368	-92.6	-3.026	-62.0
10	-1.719	133.3	-17.541	-113.8	-57.155	144.6	-4.184	-136.0
11	-1.699	90.6	-13.693	144.3	-53.686	70.0	-3.170	144.1
12	-2.040	56.7	-12.504	62.2	-55.010	3.1	-1.983	88.3
13	-2.571	27.9	-11.737	-14.7	-55.764	-39.6	-1.258	49.1
14	-3.060	3.3	-11.646	-87.6	-59.179	-66.7	-1.002	18.6
15	-3.508	-18.5	-11.675	-156.1	-74.614	-164.1	-0.846	-8.9
16	-3.735	-38.8	-12.726	130.9	-67.969	-27.3	-0.824	-34.4
17	-3.848	-58.4	-14.888	68.4	-66.320	150.5	-0.820	-59.4
18	-3.912	-76.7	-17.829	5.8	-54.010	62.9	-0.879	-84.0
19	-3.974	-93.7	-20.842	-29.7	-54.118	10.4	-0.963	-108.6
20	-4.100	-111.1	-21.495	-64.3	-59.533	-43.8	-1.009	-133.1
21	-4.284	-127.3	-20.461	-106.8	-51.661	4.6	-1.077	-158.5
22	-4.493	-144.4	-20.767	-166.1	-50.166	-19.8	-1.144	176.5
23	-5.047	-160.8	-24.635	131.9	-50.208	-29.2	-1.232	148.6
24	-5.677	-179.4	-32.559	105.5	-46.109	-60.2	-1.343	119.5
25	-6.576	160.5	-34.751	146.0	-48.584	-95.9	-1.382	87.0
26	-7.611	138.2	-25.865	142.4	-48.804	-111.0	-1.533	51.9
27	-9.026	114.2	-18.211	110.4	-53.102	-97.9	-1.697	13.5
28	-10.432	84.8	-11.171	67.0	-48.146	-83.4	-2.076	-26.6
29	-11.462	52.8	-4.033	16.9	-43.460	-105.3	-2.614	-68.4
30	-12.151	18.0	3.183	-42.0	-40.803	-128.6	-3.767	-112.1
31	-12.392	-17.8	10.493	-114.2	-39.522	-155.6	-6.784	-154.8
32	-14.074	-74.7	16.821	158.0	-41.853	163.5	-11.689	-165.5
33	-20.113	-163.1	20.193	59.6	-48.557	126.2	-8.740	-176.8
34	-16.515	103.7	21.637	-32.6	-58.779	157.1	-8.201	141.5
35	-11.630	56.4	22.299	-120.9	-51.625	-130.7	-9.119	109.3
36	-8.811	16.2	22.904	150.2	-40.404	-141.2	-8.759	73.3
37	-9.518	-17.5	22.591	63.2	-36.969	-172.4	-10.012	29.4
38	-14.804	-37.3	22.190	-26.3	-35.717	154.6	-14.730	-20.6
39	-21.807	8.8	21.602	-118.3	-35.336	136.7	-24.035	-108.2
40	-13.007	22.7	20.100	150.4	-33.514	117.5	-15.182	116.8
41	-16.168	-79.4	20.158	56.2	-29.583	95.2	-13.109	104.6
42	-2.320	96.3	16.630	-84.0	-29.616	21.5	-2.140	83.2
43	-1.587	44.0	5.452	175.1	-36.809	1.0	-1.539	39.6
44	-1.476	23.4	-4.040	99.2	-41.728	-3.1	-1.423	16.0
45	-1.113	7.6	-12.822	32.2	-41.809	10.1	-1.120	-2.7

Typical Board Measurements

Tcase = +25°C, Vd = +6.0V, Id = 800mA

Measurement performed in the access plans of the QFN, using the proposed land pattern & board, as defined in paragraph "Evaluation mother board"

Gain & Return Loss vs. Frequency & Gate Voltage (Vg1 & 2)

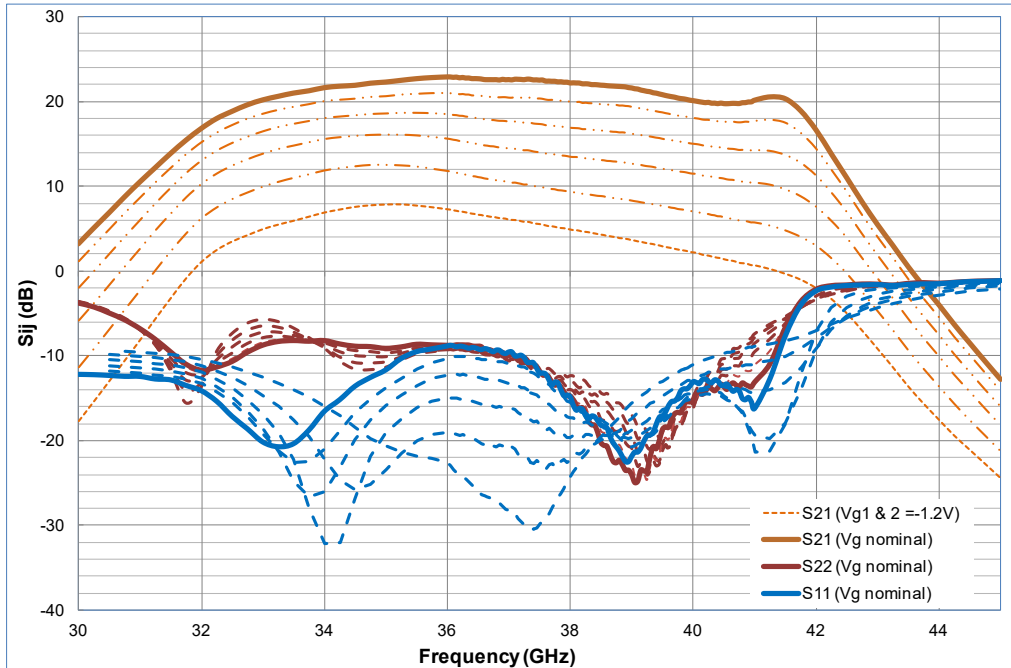

Gain control & current vs. Gate Voltage (Vg1 & 2)

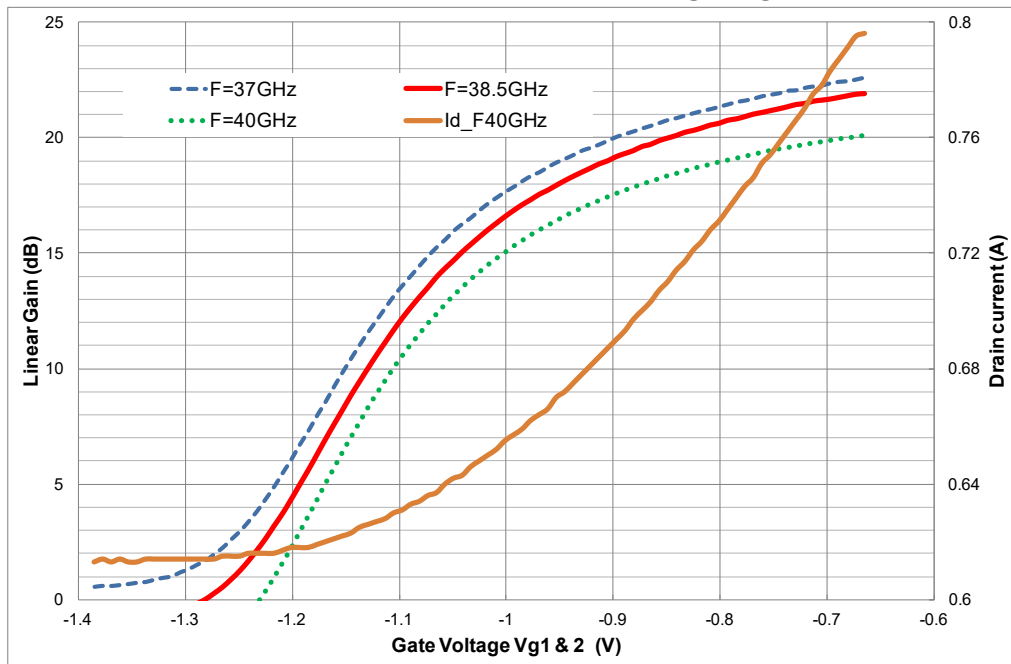

Typical Board Measurements

Tcase = +25°C, Vd = +6.0V, Id = 800mA

Gain & Return Loss vs. Frequency & Gate Voltage (Vg1,2,3,4)

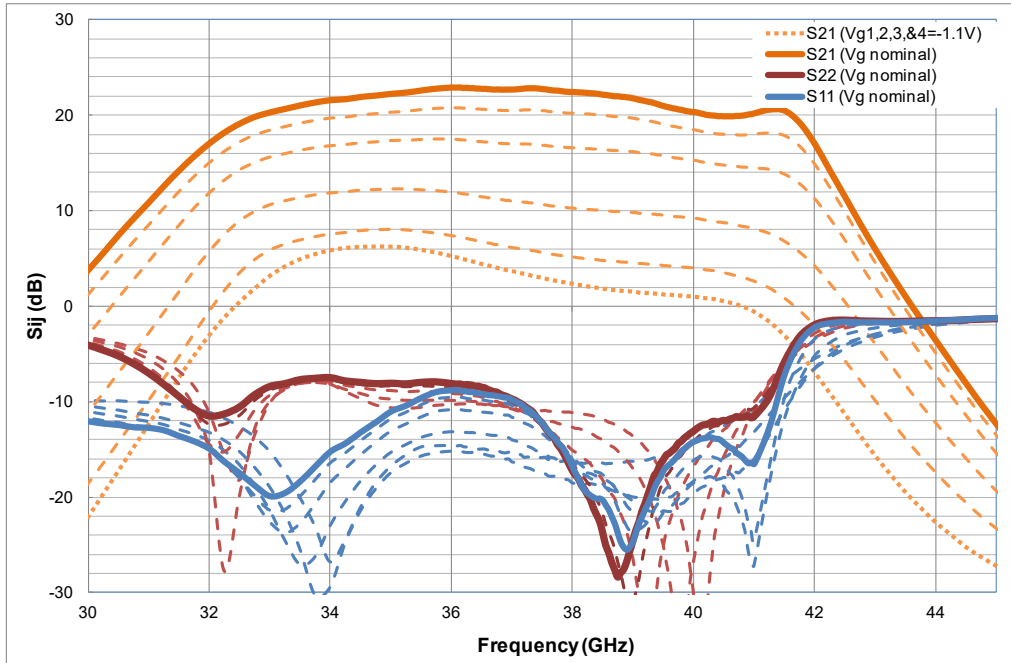

Gain control & current vs. Gate Voltage (Vg1,2,3,4)

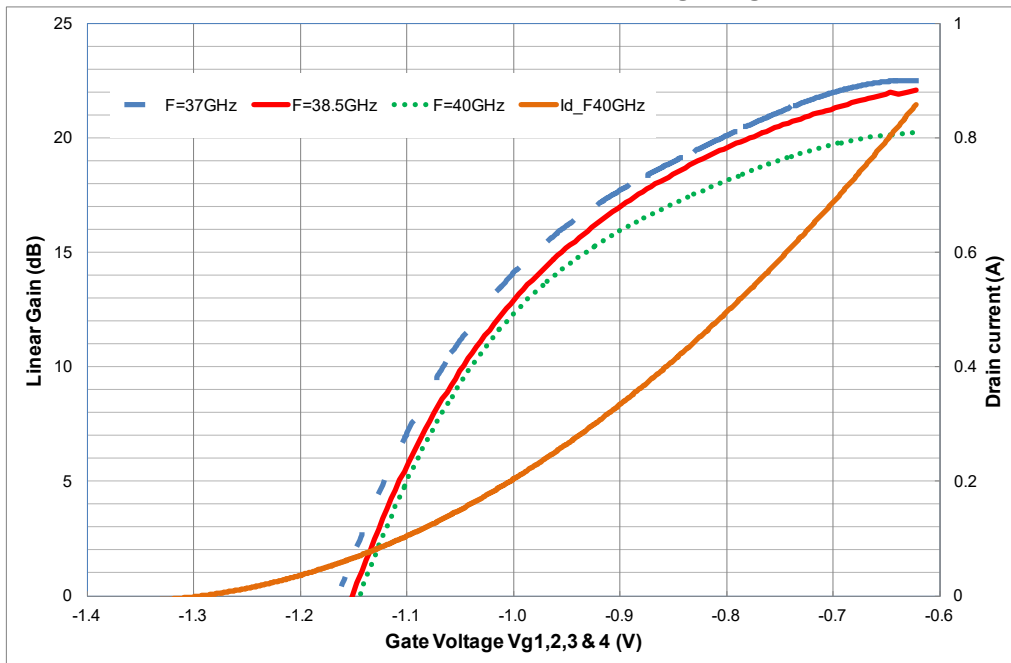

Typical Board Measurements

Tcase = +25°C, Vd = +6.0V, Id = 800mA

Output Power vs. Frequency

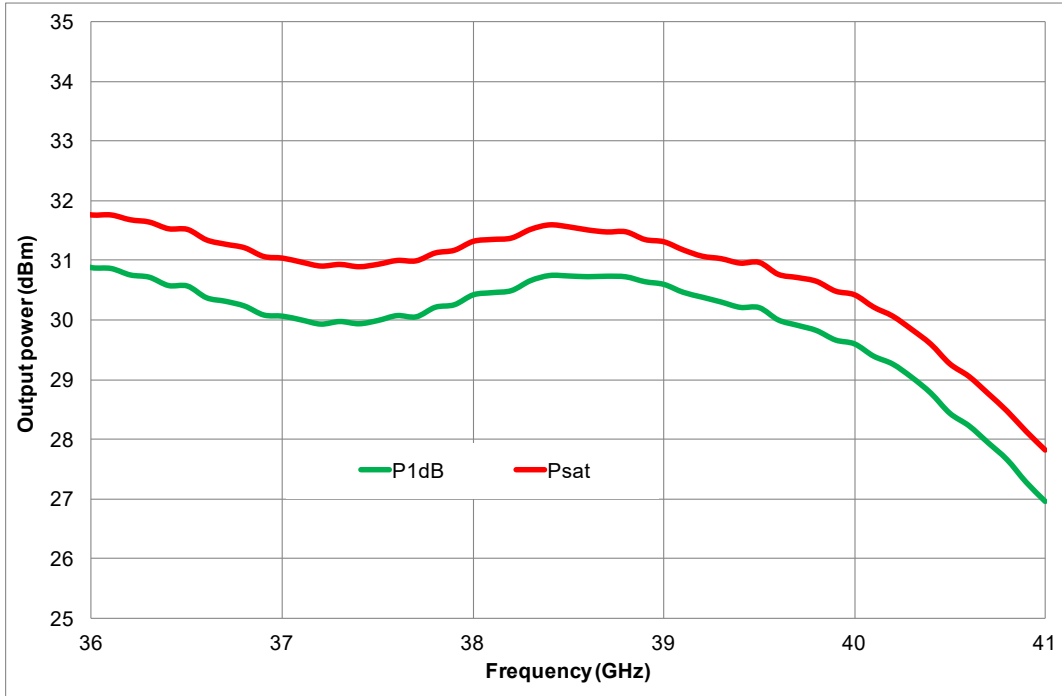

PAE vs. Output power

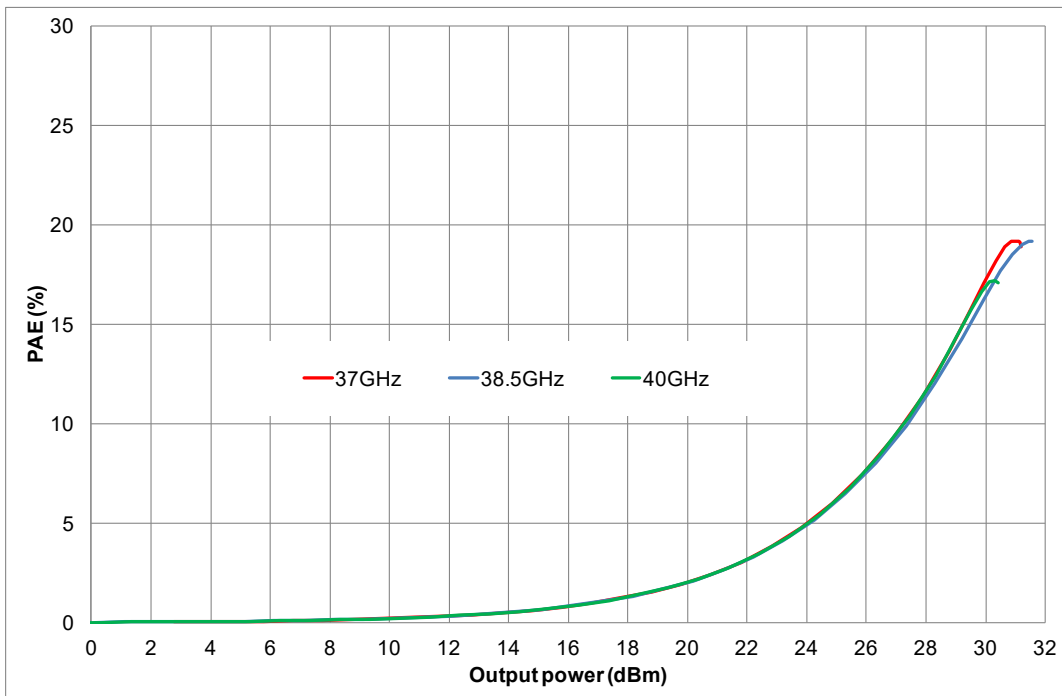

Typical Board Measurements

T_{case} = +25°C, V_d = +6.0V, I_d = 800mA

Amplitude & Phase variation vs. Output Power

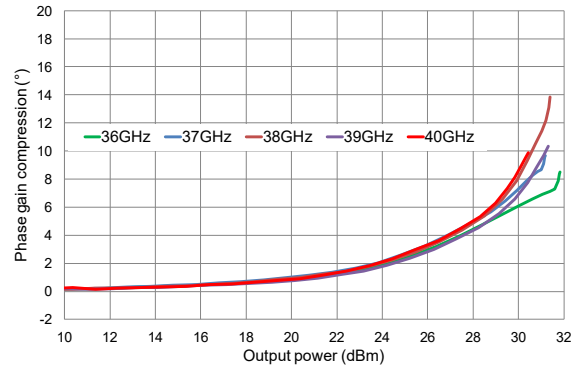
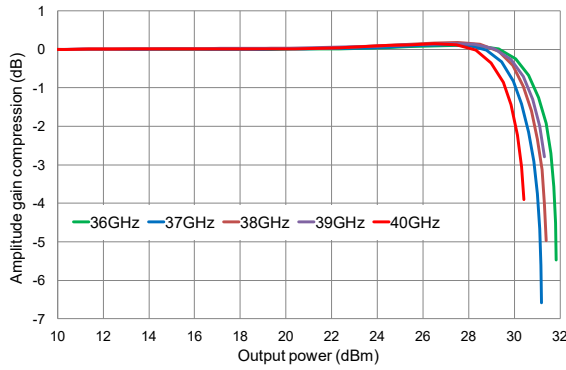

Output IP3 & IMD3 vs. Output Power

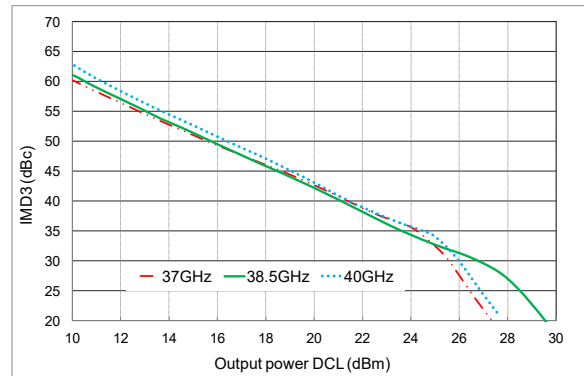
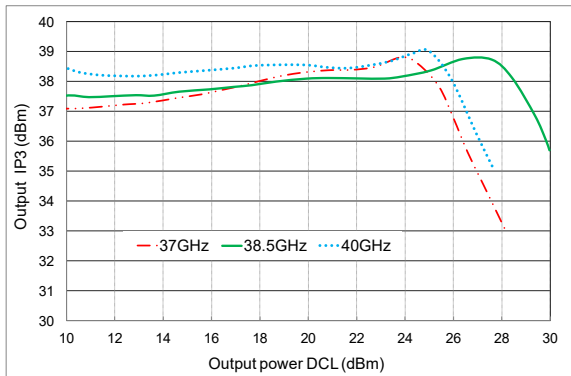

Total Drain Current vs. Output Power

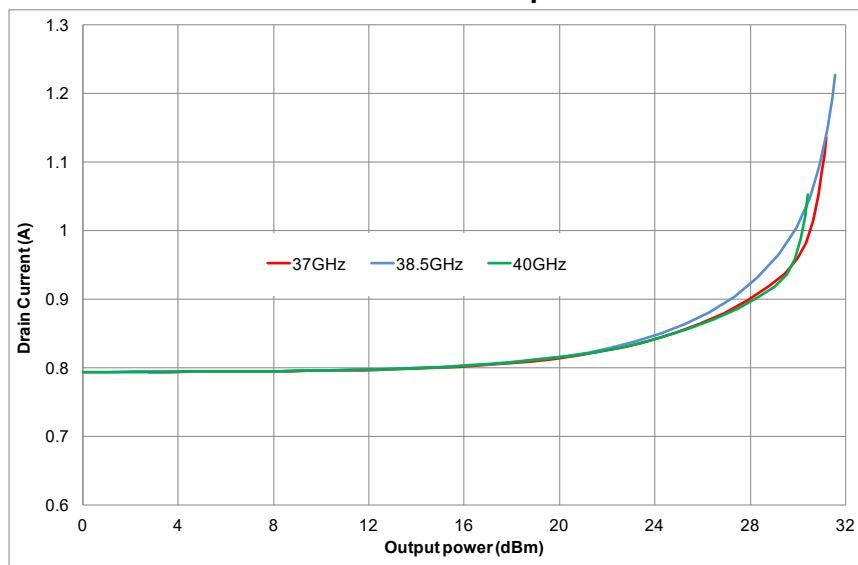

Typical Board Measurements

Tcase = +25°C, Vd = +6.0V, Id = 800mA

Power Detector vs. Output power

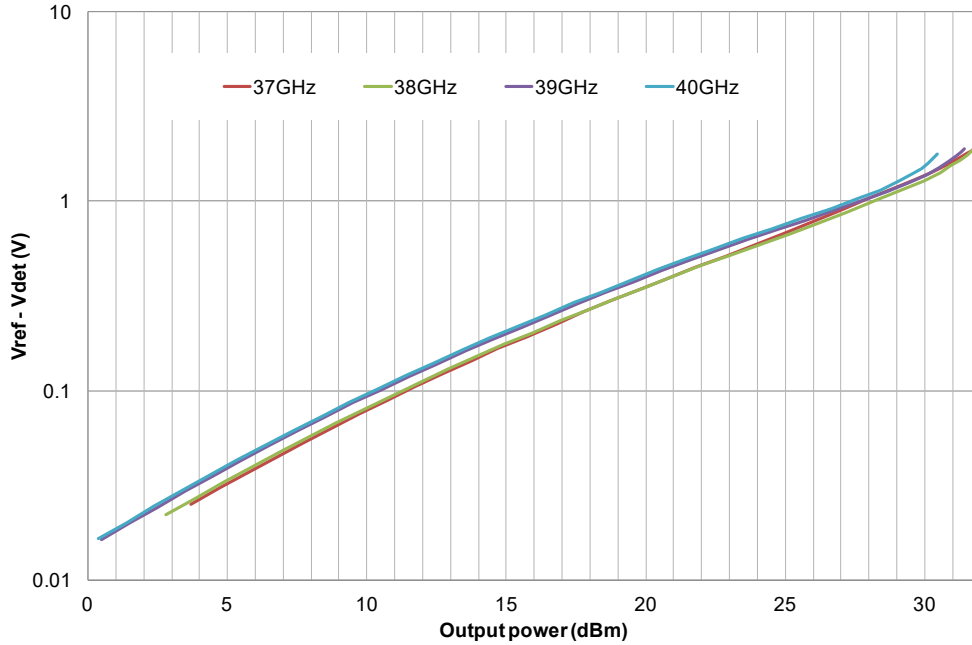

Gain variation with temperature

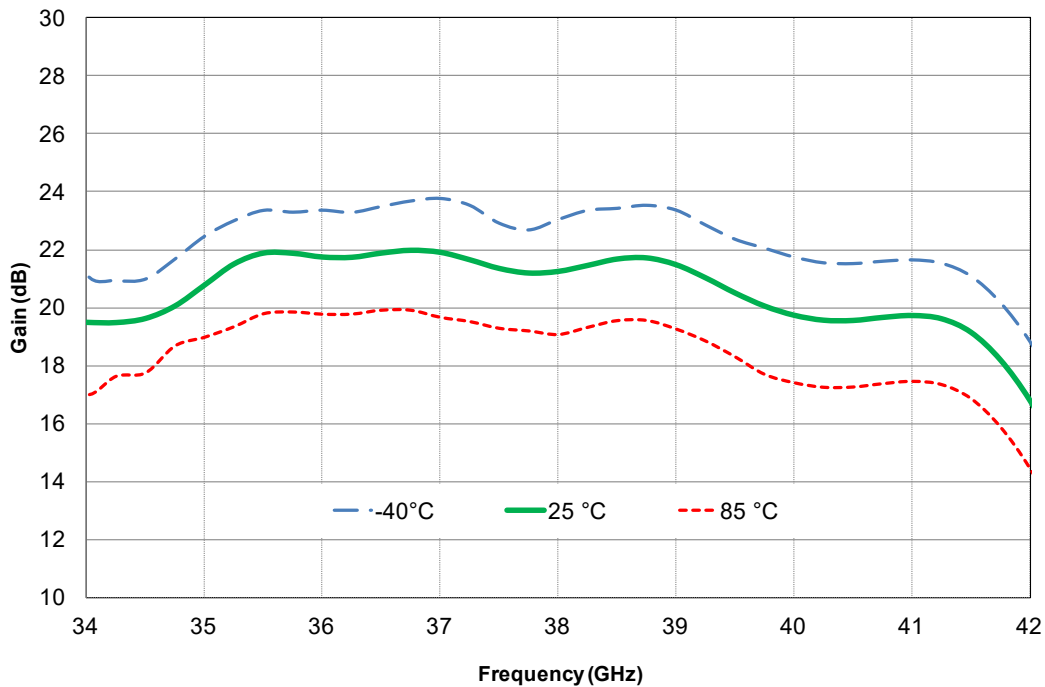

Package outline ⁽¹⁾

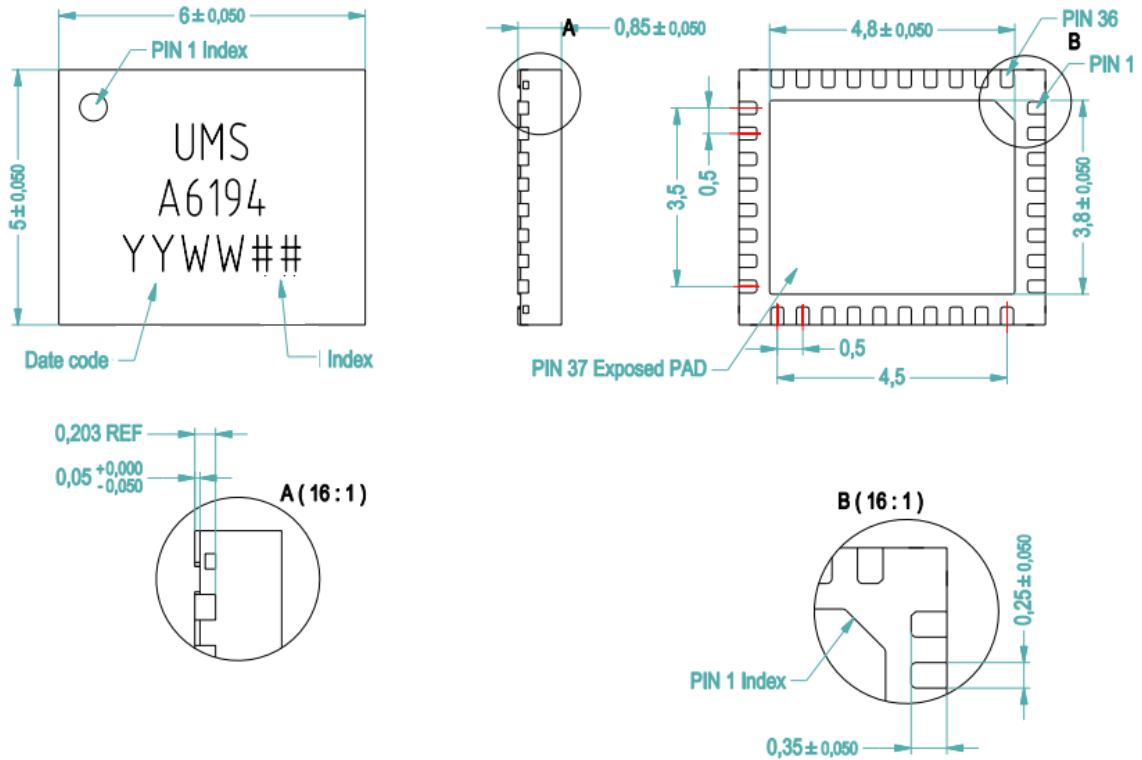

Matte tin, Lead Free (Green)	1- DET	13- GND ⁽²⁾	25- Vd4
Units : mm	2- Vd4	14- RF in	26- NC
From the standard : JEDEC MO-220 (VHJD)	3- Vg4	15- GND ⁽²⁾	27- GND ⁽²⁾
	4- Vd3	16- NC	28- NC
37- GND	5- Vg3	17- NC	29- NC
	6- Vd2	18- NC	30- GND ⁽²⁾
	7- Vd1	19- Vg1	31- RF out
	8- NC	20- NC	32- GND ⁽²⁾
	9- NC	21- Vg2	33- NC
	10- NC	22- Vg3	34- NC
	11- NC	23- Vd3	35- NC
	12- NC	24- Vg4	36- REF

⁽¹⁾ Refer to the application note AN0017 (<https://www.ums-rf.com>) for general consideration and recommendations for Molded Plastic QFN/DFN packages.

⁽²⁾ It is strongly recommended to ground all pins marked “GND” through the PCB board. Ensure that the PCB board is designed to provide the best possible ground to the package.

Definition of the Sij reference planes

The reference planes used for Sij measurements given above are symmetrical from the symmetrical axis of the package (see drawing beside). The input and output reference planes are located at 3.77mm offset (input wise and output wise respectively) from this axis. Then, the given Sij parameters incorporate the land pattern of the evaluation motherboard recommended in paragraph "Evaluation mother board".

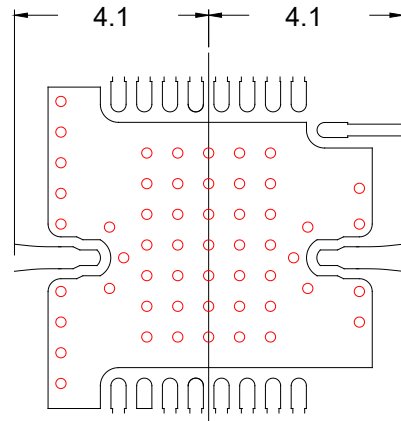

ESD sensitivity

Standard	Value
JEDEC JESD22 A114D	HBM Class 0 (200V)

Package Information

Parameter	Value
Package body material	RoHS-compliant
	Low stress Injection Molded Plastic
Lead finish	100% matte tin (Sn)
MSL Rating	MSL3

Evaluation board

- Compatible with the proposed footprint.
- Based on typically Ro4350B / 10mils or equivalent.
- Using a micro-strip to coplanar transition to access the package.
- Recommended for the implementation of this product on a module board.
- Decoupling capacitors of 100pF \pm 5%, 10nF \pm 10% and 1 μ F \pm 10% are recommended for all DC accesses.
- A 10K Ω resistor is recommended on VREF & VDET accesses for the detector
- See application note AN0017 for details.

Note: All board measurements are performed using **shielded cables**, even for DC bias, to ensure safe operation.

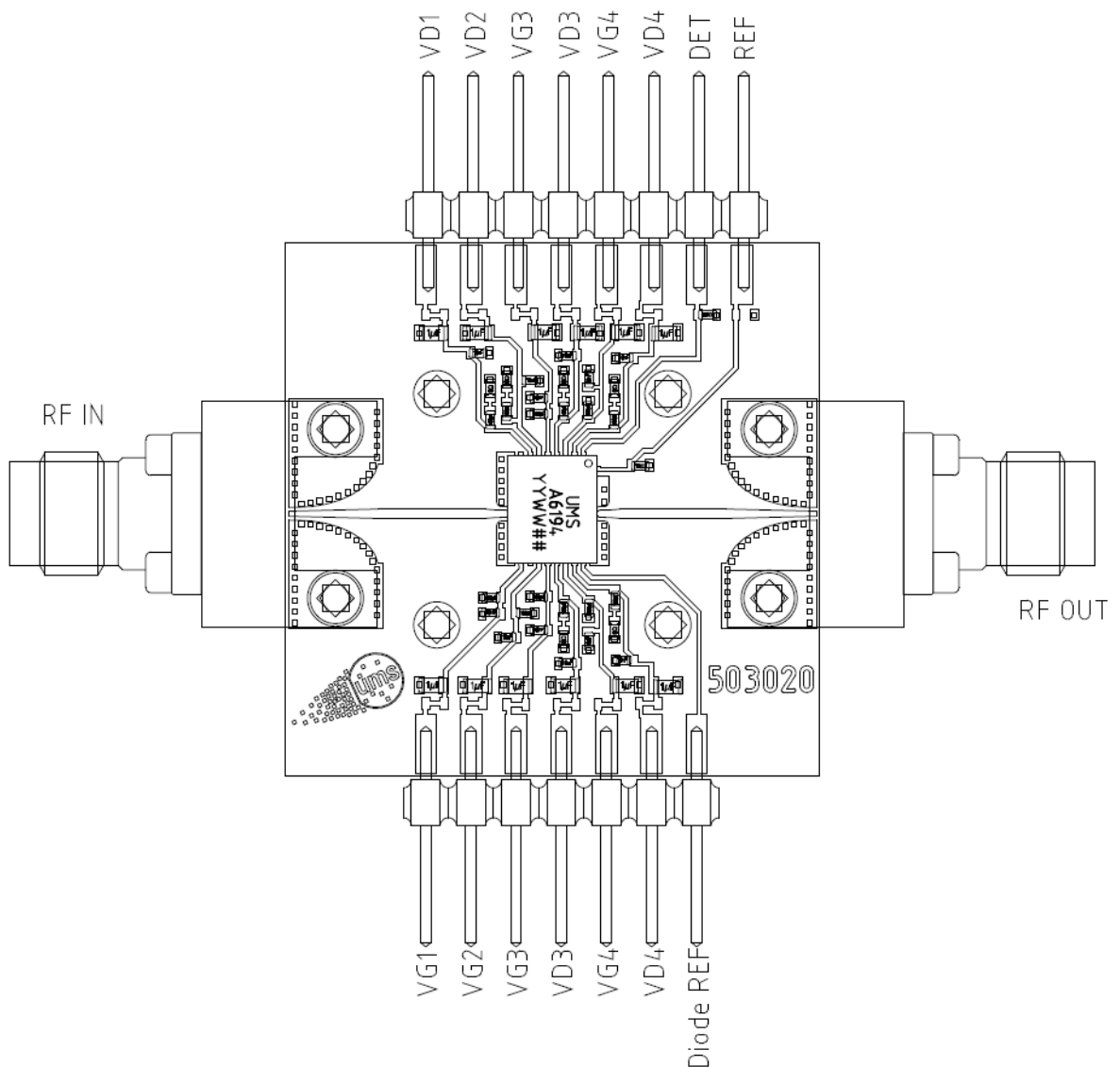

Notes

Due to ESD protection circuits on RF input and output, an external capacitance might be requested to isolate the product from external voltage that could be present on the RF accesses.

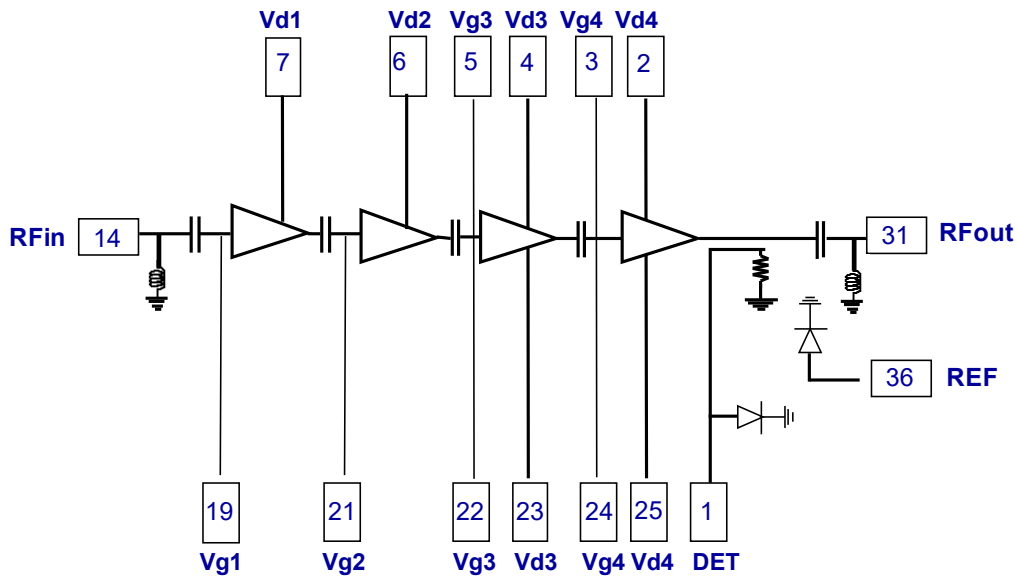

The DC connections do not include any decoupling capacitor in package, therefore it is mandatory to provide a good external DC decoupling (100pF, 10nF, 1µF) on the PC board, as close as possible to the package.

A 10KΩ resistor is recommended in parallel to VDET, and VREF accesses.

The circuit includes ESD protections on all RF and DC leads

DC Schematic

6V, 800mA

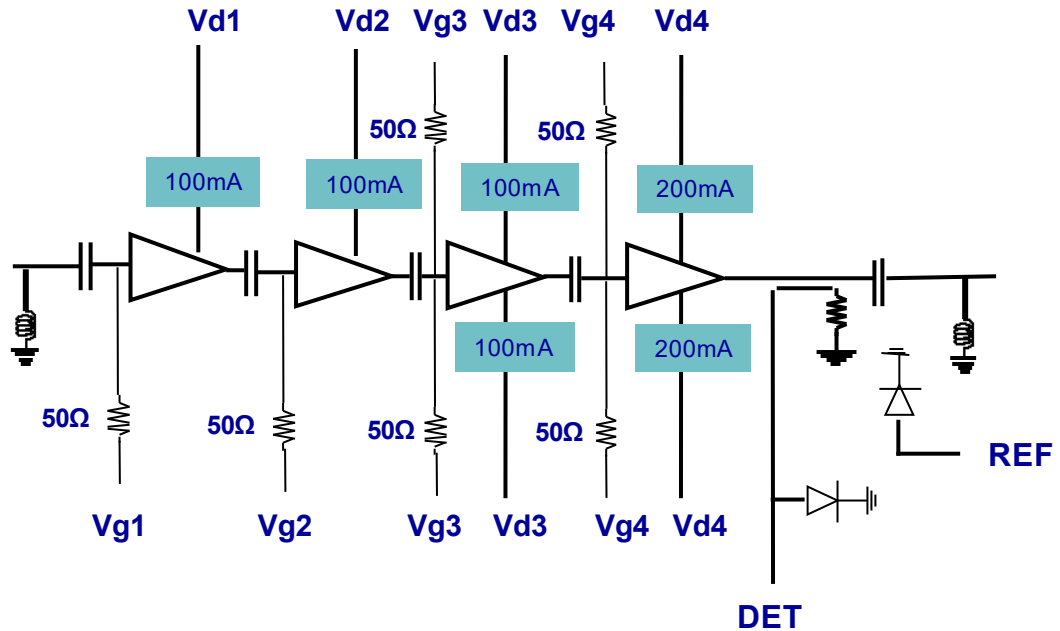

Recommended UMS Power chain

The CHA6194-QXG is recommended with the CHA3397-QDG as driver.

Total Gain: 41dB

Gain control: 30dB for both amplifiers.

For more information about CHA3397-QDG, see our [web site](#).

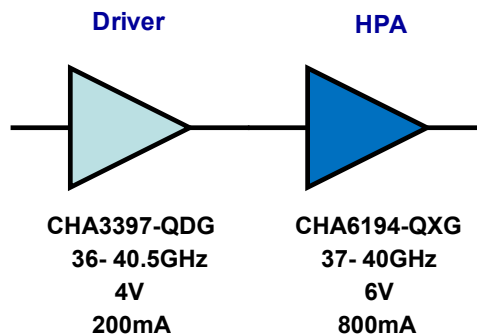

SMD mounting procedure

For the mounting process standard techniques involving solder paste and a suitable reflow process can be used. For further details, see application note AN0017.

Recommended environmental management

UMS products are compliant with the regulation in particular with the directives RoHS N°2011/65 and REACH N°1907/2006. More environmental data are available in the application note AN0019 also available at <https://www.ums-rf.com>.

Recommended ESD management

Refer to the application note AN0020 available at <https://www.ums-rf.com> for ESD sensitivity and handling recommendations for the UMS package products.

Ordering Information

QFN 6x5 package:

CHA6194-QXG/XY

Stick: XY = 20

Tape & reel: XY = 21

Information furnished is believed to be accurate and reliable. However **United Monolithic Semiconductors S.A.S.** assumes no responsibility for the consequences of use of such information nor for any infringement of patents or other rights of third parties which may result from its use. No license is granted by implication or otherwise under any patent or patent rights of **United Monolithic Semiconductors S.A.S.**. Specifications mentioned in this publication are subject to change without notice. This publication supersedes and replaces all information previously supplied. **United Monolithic Semiconductors S.A.S.** products are not authorised for use as critical components in life support devices or systems without express written approval from **United Monolithic Semiconductors S.A.S.**