

## 17- 21GHz Medium Power Amplifier

### GaAs Monolithic Microwave IC in SMD Hermetic package

#### Description

The CHA4253-FAB is a four stage monolithic GaAs Medium Power Amplifier circuit delivering 23.5dBm output power at 1dB compression point.

It is designed for a wide range of applications, commercial space, military and commercial communication systems. The circuit is manufactured with an internal robust space evaluated 0.15µm gate length pHEMT process.

It is supplied in a hermetic package.

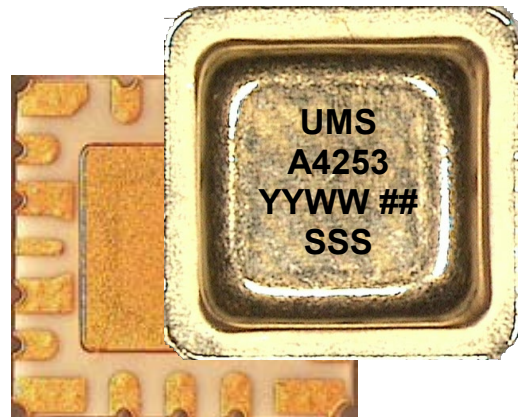

#### Main Features

- Broadband performances: 17- 21GHz
- 23.5dBm Pout for 1dB gain compression
- 26dB Linear Gain
- 33dBm Output IP3
- DC bias: Vd= 4.0V, Id= 230mA
- 20Leads-SMD
- 6x6mm<sup>2</sup> metal ceramic hermetic package

Output power & PAE versus Frequency

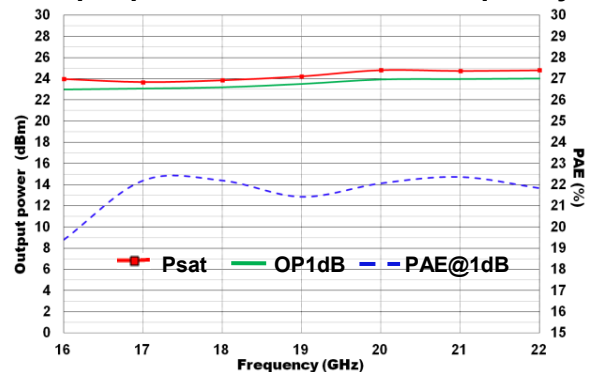

#### Main Electrical Characteristics

Tcase.= +25°C

Symbol	Parameter	Min	Typ	Max	Unit
Freq	Frequency range	17.0		21.0	GHz
Gain	Linear Gain		26		dB
P-1dB	Output Power @1dB comp.		23.5		dBm
OIP3	3 <sup>rd</sup> order Intercept point		33		dBm

## Electrical Characteristics

Tamb.= +25°C, Vd = +4.0V

Symbol	Parameter	Min	Typ	Max	Unit
Freq	Frequency range	17.0		21.0	GHz
Gain	Linear Gain		26		dB
ΔG	Gain variation in temperature		0.05		dB/°C
OIP3	3 <sup>rd</sup> order Intercept point		33		dBm
P <sub>-1dB</sub>	Output power @ 1dB compression		23.5		dBm
Psat	Saturated Output Power		24.5		dBm
RLin	Input Return Loss		15		dB
RLout	Output Return Loss		12		dB
Id	Quiescent Drain current		230		mA
Vg	Gate voltage		-0.7		V

These values are representative of onboard measurements

## Recommended Operating Ratings

Tcase.= +25°C

Symbol	Parameter	Values	Unit
Tj	Junction temperature	175	°C

## Absolute Maximum Ratings <sup>(1)</sup>

Tcase.= +25°C

Symbol	Parameter	Values	Unit
Vd	Drain bias voltage	6	V
Id	Drain bias quiescent current	300	mA
Vg	Gate bias voltage	-2 to +0.4	V
Pin	Maximum input power	+10	dBm
Ta	Operating temperature range	-40 to +85	°C
Tstg	Storage temperature range	-55 to +150	°C

<sup>(1)</sup> Operation of this device above any one of these parameters may cause permanent damage.

## Typical Bias Conditions

Tcase= +25°C

Symbol	Pad N°	Parameter	Values	Unit
Vd12	2	DC Drain voltage 1 <sup>st</sup> , 2 <sup>nd</sup> stage	4	V
Vd34	4	DC Drain voltage 3 <sup>rd</sup> , 4 <sup>th</sup> stage	4	V
Vg12	14	DC Gate voltage 1 <sup>st</sup> & 2 <sup>nd</sup> stage	-0.7	V
Vg34	13	DC Gate voltage 3 <sup>rd</sup> & 4 <sup>th</sup> stage	-0.7	V

**Device thermal information**

All the figures given in this section are obtained assuming that the FAB device is only cooled down by conduction through the package thermal pad (no convection mode considered).

The temperature is monitored at the package backside interface (Tcase).

The system maximum temperature must be adjusted in order to guarantee that Tjunction remains below the maximum value specified in the Absolute Maximum Ratings table.

So, the system PCB must be designed to comply with this requirement.

Thermal Resistance <sup>(1)</sup> Junction to backside ground paddle	Rth_eq	Tcase =85°C, Vd=4V, Id=0.445A Pin#2dBm Pout=24dBm Pdiss=1.45W CW	55.8	°C/W
Junction Temperature	Tj		166	°C
Median Life	T50		4x10 <sup>7</sup>	Hrs

<sup>(1)</sup> Thermal resistance measured at back side of the package

Median Life Time versus Junction Temperature

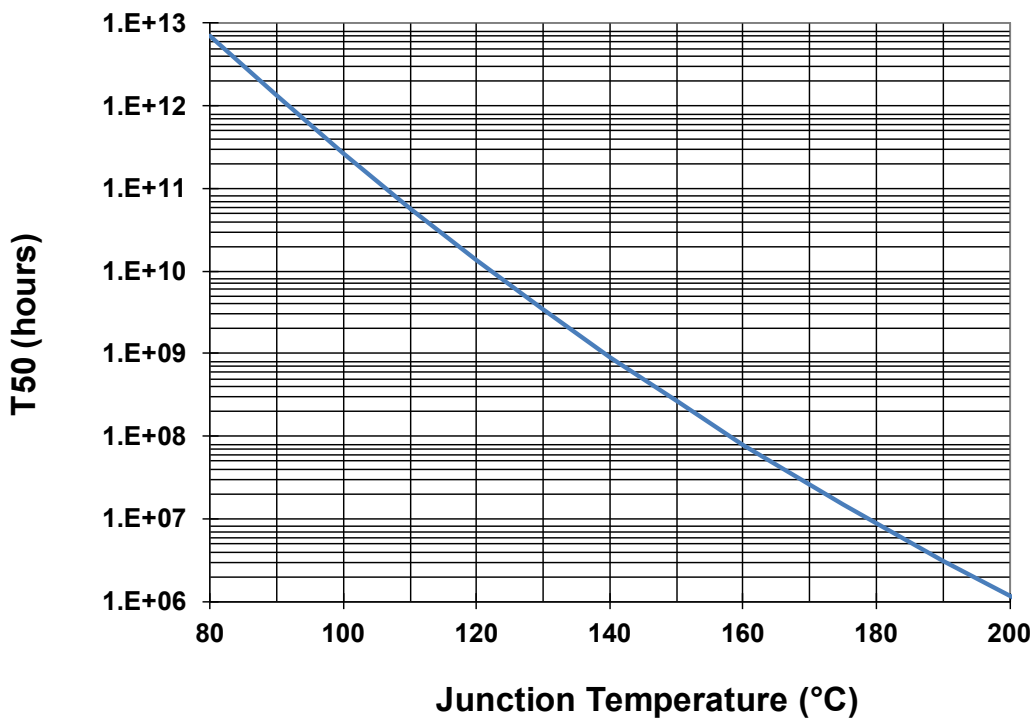

## Typical Package Sij parameters

Tcase= +25°C, Vd = +4.0V, Idq = 230mA

Freq (GHz)	S11 (dB)	PhS11 (°)	S12 (dB)	PhS12 (°)	S21 (dB)	PhS21 (°)	S22 (dB)	PhS22 (°)
1	-0.61	144.35	-79.12	37.33	-75.75	55.63	-0.6	148.61
2	-0.75	108.35	-73.88	20.49	-72.01	14.68	-0.72	117.1
3	-0.92	71.87	-73.41	-13.71	-75.29	-48.81	-0.85	84.82
3.5	-1.01	53.16	-75.16	-2.23	-78.33	-51.23	-0.92	68.04
4	-1.12	34.08	-73.48	-28.91	-71.66	-175.38	-0.98	50.97
4.5	-1.3	14.57	-74.8	-51.86	-67.56	108.81	-1.05	33.43
5	-1.57	-4.96	-76.81	-65.63	-51.42	166.42	-1.1	15.49
5.5	-1.91	-23.62	-79.94	-77.69	-34.26	76.96	-1.15	-2.99
6	-2.11	-41.25	-77.03	-106.46	-27.2	-12.82	-1.2	-21.91
6.5	-2.25	-60.94	-82.67	-137.54	-23.3	-80.62	-1.23	-41.95
7	-2.32	-80.52	-92.75	-121.52	-20.02	-134.72	-1.27	-62.25
7.5	-2.42	-100.49	-83.61	-141.84	-16.84	177.08	-1.34	-83.31
8	-2.6	-120.68	-75.4	-135.15	-13.77	131.89	-1.5	-105.16
8.5	-2.83	-140.93	-66.67	-156.94	-10.81	88.47	-1.76	-128.08
9	-3.15	-161.27	-61.24	166.03	-8	46.02	-2.21	-152.24
9.5	-3.53	178.45	-59.32	116.75	-5.41	3.96	-2.9	-177.74
10	-4	157.97	-56.46	80.8	-3.17	-35.84	-3.74	155.01
10.5	-4.53	137.51	-61.13	38.87	-0.73	-75.81	-4.99	125.51
11	-5.15	116.93	-60.59	27.83	1.35	-115.27	-6.34	94.32
11.5	-5.85	95.76	-62.62	5.66	3.27	-153.78	-7.69	60.95
12	-6.66	74.46	-66.32	-18.92	5.08	169.14	-8.78	27.26
12.5	-7.57	52.72	-74.83	10.16	6.87	133.19	-9.47	-5.27
13	-8.62	30.54	-71.99	76.55	8.73	98.42	-9.79	-34.88
13.5	-9.79	7.8	-64.52	97.68	10.74	64.4	-9.91	-60.53
14	-11.13	-15.81	-56.96	84.48	12.99	30.21	-9.97	-83.6
14.5	-12.71	-39.7	-57.81	64.95	15.44	-5.08	-10.34	-106
15	-14.59	-63.57	-52.68	42.89	18.04	-41.93	-11.39	-128.08
15.5	-17.03	-84.95	-50.94	18.52	20.85	-80.98	-13.53	-148.14
16	-20.33	-98.91	-51.43	-3.31	23.82	-124.08	-18.12	-158.74
16.5	-19.58	-86.88	-50.59	-27.34	26.31	-171.68	-25.66	-89.92
17	-15.32	-102.15	-54.47	-33.56	28.22	137.56	-14.19	-77.31
17.5	-14.05	-143.96	-53.95	-26.21	29.61	82.07	-10	-110
18	-15.49	177.06	-49.91	-35.99	29.27	27.55	-9.59	-137.79
18.5	-18.61	154.01	-48.35	-52.82	28.29	-17.87	-11.03	-154.83
19	-22.88	161.01	-48.11	-81.7	27.55	-57.89	-13.44	-155.89
19.5	-19.93	171.37	-51.44	-96.78	27.23	-96.12	-13.5	-150.3
20	-16.93	154.97	-51.23	-117.4	27.34	-134.43	-11.93	-147.78
20.5	-17.09	135.91	-58.08	-135.02	27.21	-172.86	-11.77	-160.68
21	-16.25	125.97	-68.78	-44.57	27.49	149.37	-11.89	-159.27
21.5	-13.23	112.95	-50.53	-69.03	28.11	109.35	-9.86	-154.73
22	-12.24	85.3	-49.71	-98.32	28.18	66.17	-8.71	-172.06
22.5	-12.84	51.15	-51.93	-125.58	27.5	24.5	-9.39	171.13
23	-14.26	22.12	-55	-106.28	27.29	-13.42	-10.53	165.12
23.5	-16.98	-10.15	-53.06	-103.66	27.32	-51.06	-11.95	158.77
24	-20.23	-47.02	-51.66	-88.48	27.96	-91.82	-12.66	159.38
24.5	-21.57	-131.28	-49.36	-113.86	28.73	-136.57	-14.51	164.84
25	-16.37	162.45	-47.1	-107.05	29.22	174.26	-17.65	-177.8
25.5	-13.87	115.17	-46.43	-132.8	28.64	115.78	-15.81	-160.82
26	-12.31	86.14	-44.77	-137.61	26.78	59.33	-10.68	-152.64

### Typical Board Measurements

Vd = +4.0V. Idq = 230mA

These values are representative of onboard measurements as defined on the drawing in paragraph "Evaluation mother board". Measurements in the planes of the connectors. Board losses have been taken into account to plot the following measurements below.

Linear Gain versus Frequency in Temperature

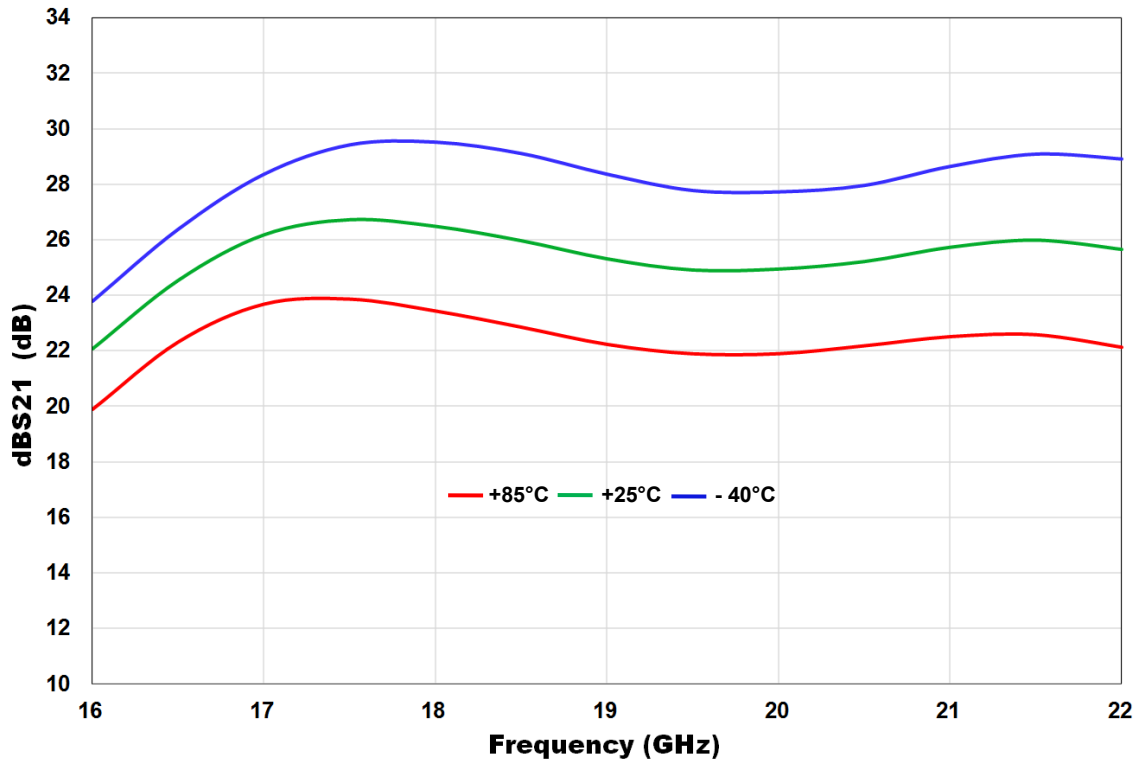

Return losses versus Frequency in Temperature

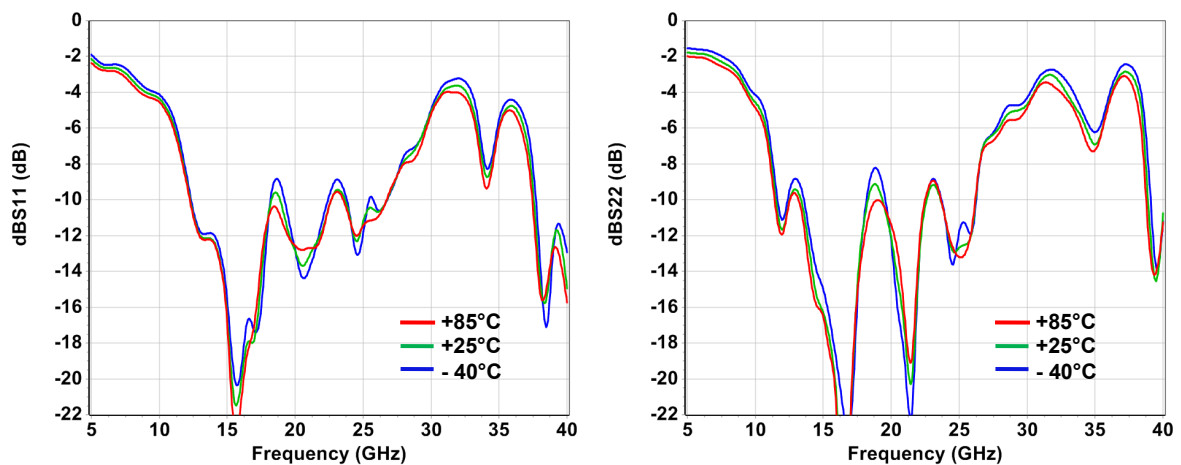

## Typical Board Measurements

Tcase= +25°C. Vd = +4.0V. Idq = 230mA. Measurements in packaging planes.

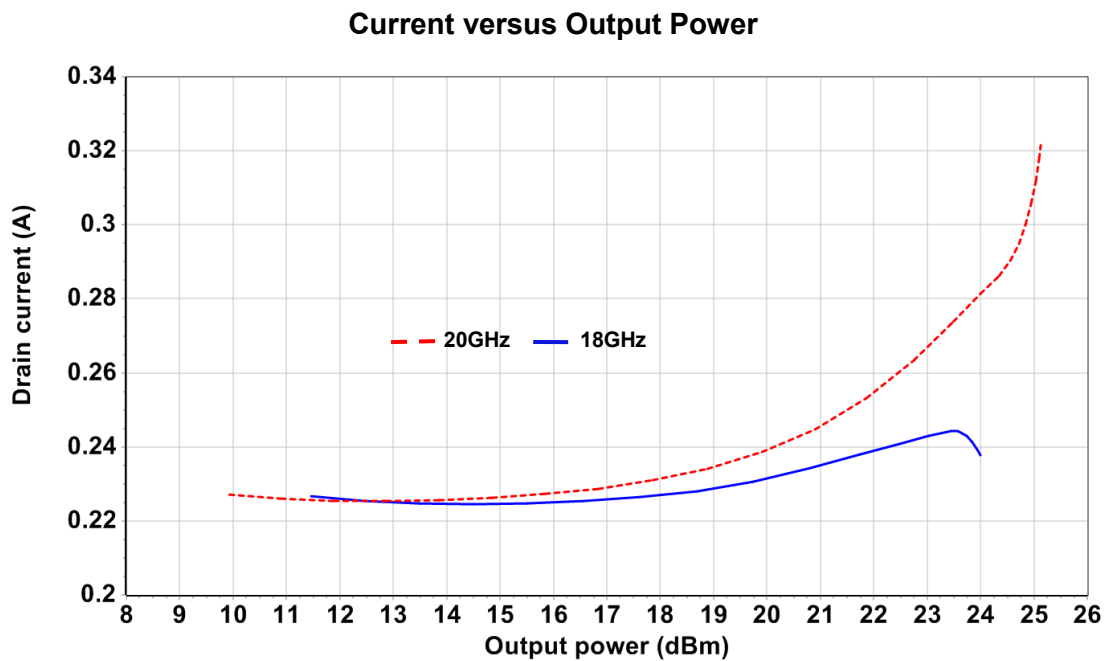
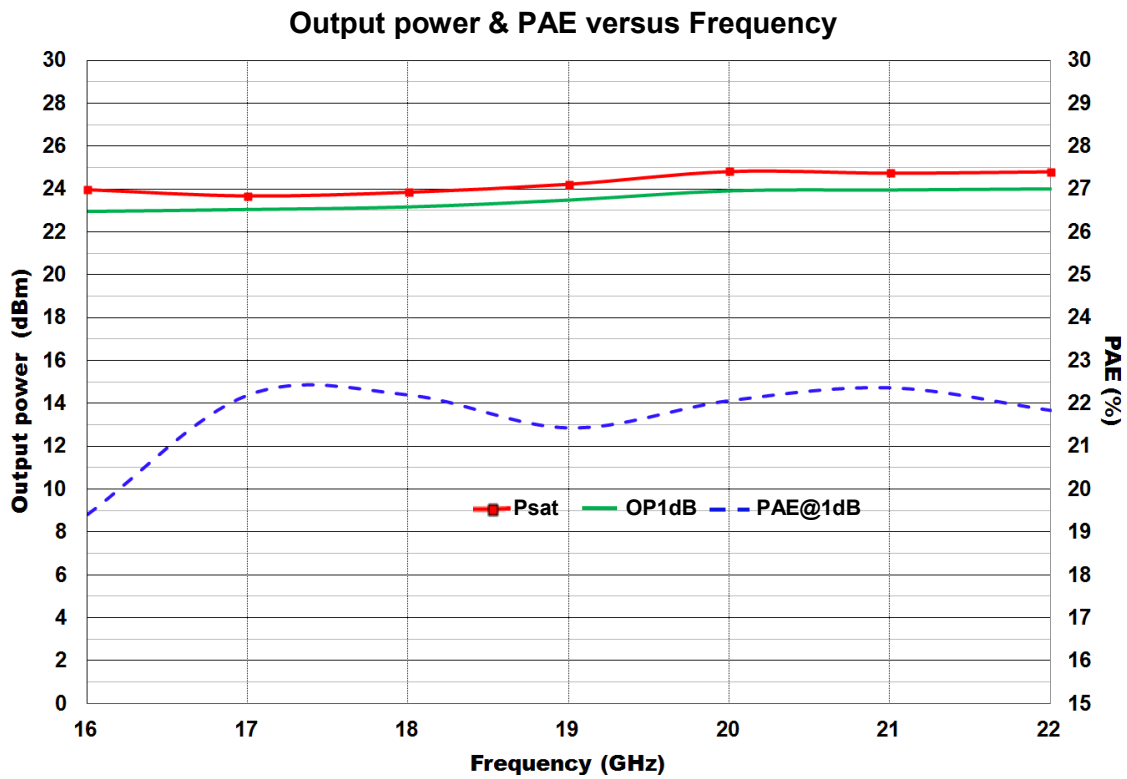

**Typical Board Measurements**

Vd = +4.0V. Idq = 230mA. Measurements in packaging planes.

**Output power versus Input power and Temperature at 19GHz**

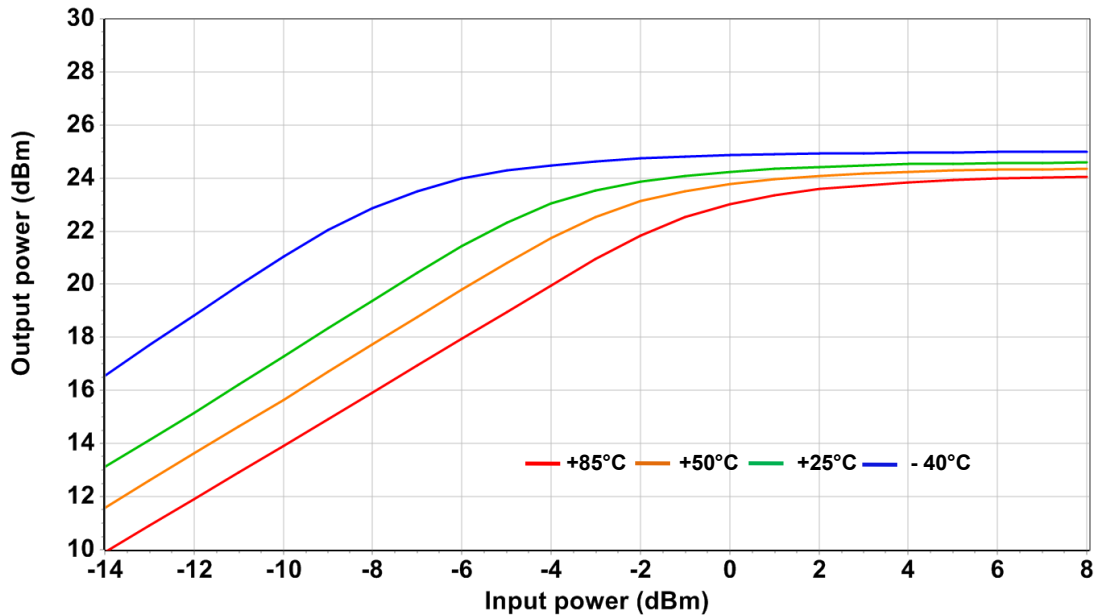

**Output power at 1dB compression versus Temperature and Frequency**

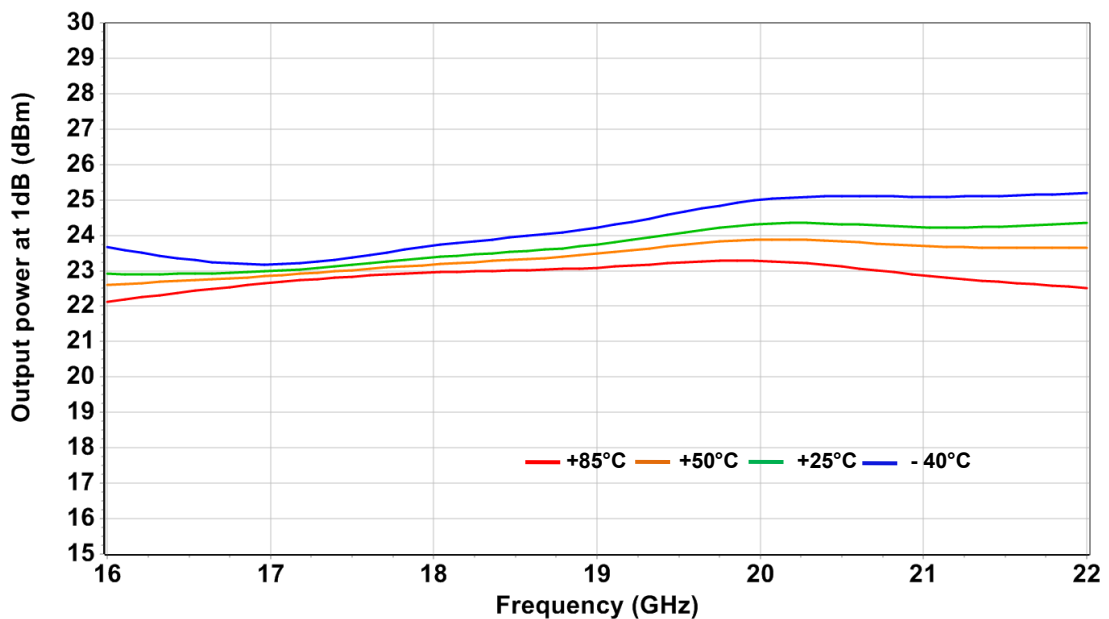

## Typical Board Measurements

Tcase= +25°C. Vd = +4.0V. Idq = 230mA. Measurements in packaging planes.

**Output IP3 versus Output Power DCL & Frequency**

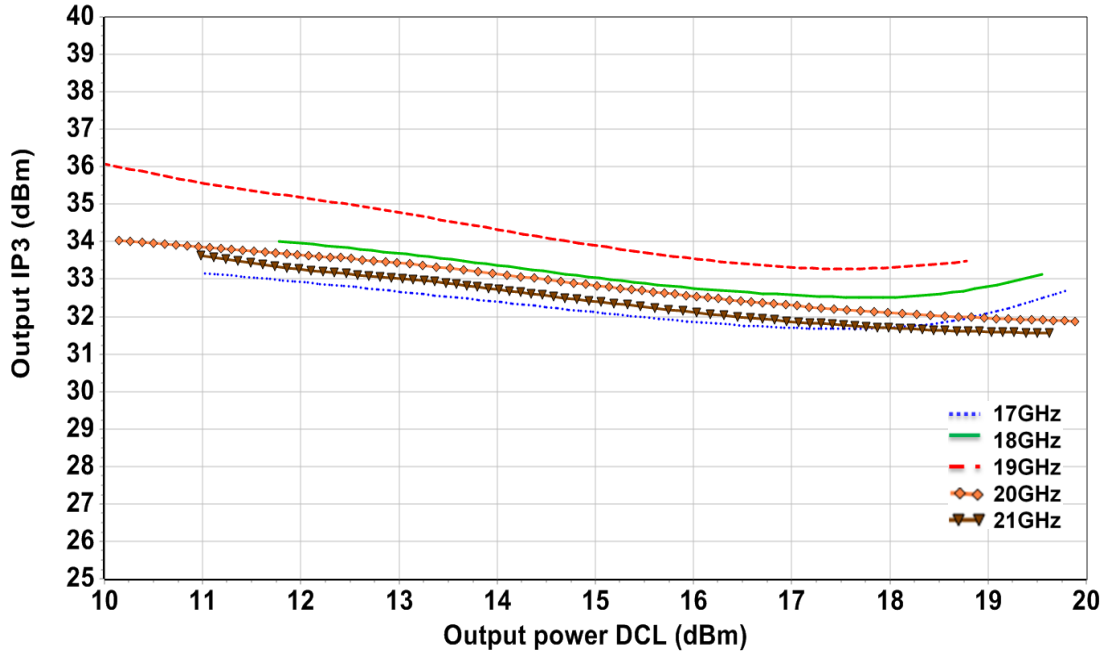

**Output IP3 versus Output Power DCL in Temperature at 20GHz**

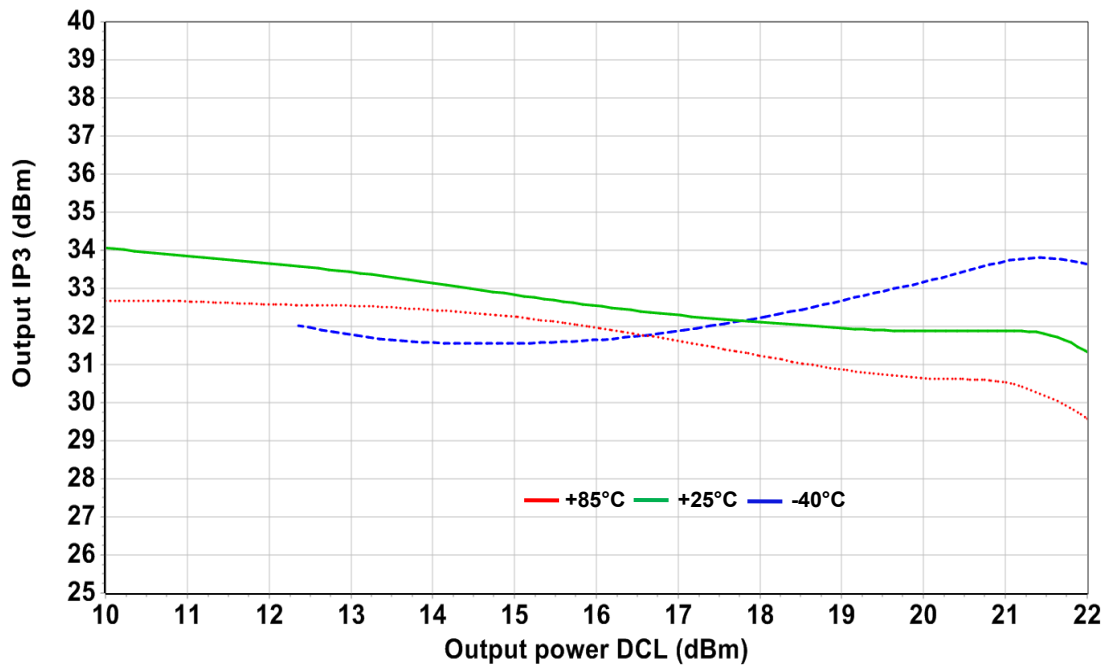

Package outline (1)

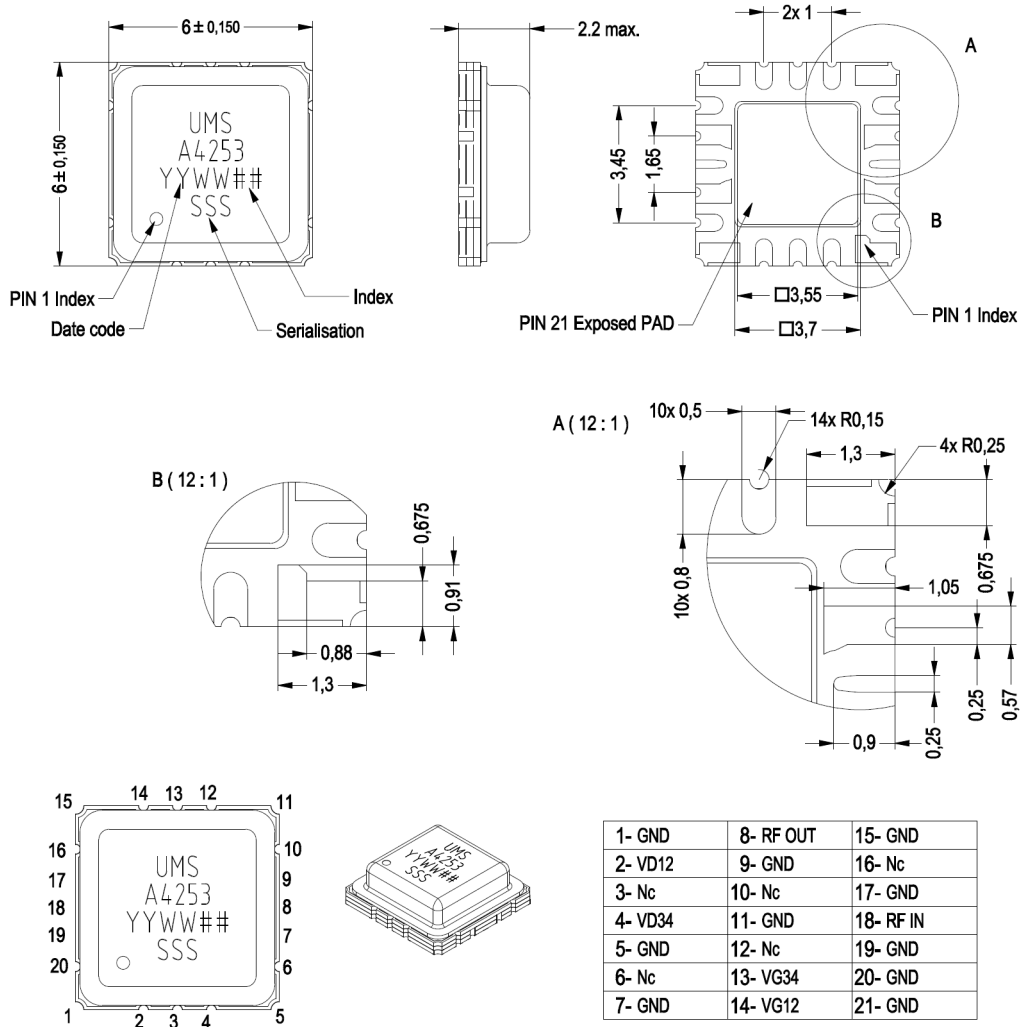

Units : mm

(1) The package outline drawing included to this data-sheet is given for indication. Refer to the application note AN0024 (<https://www.ums-rf.com>) for exact package dimensions.

It is strongly recommended to ground all pins marked “Gnd” through the PCB board. Ensure that the PCB board is designed to provide the best possible ground to the package.

Package Information

Parameter	Value
Package body material	RoHS-compliant
Lead finish	Gold
Hermetic sealing (fine leak compliant Mil-Std-883 Method 1014.10 Condition A4, tracer gas He at 1atm)	1x10 <sup>-8</sup> ccHe/s/atm

## Evaluation mother board

- Compatible with the proposed footprint.
- Based on typically Ro4003 / 8mils or equivalent.
- Using a micro-strip to coplanar transition to access the package.
- Recommended for the implementation of this product on a module board.
- Decoupling capacitors of 100pF  $\pm 5\%$  & 10nF  $\pm 10\%$  are recommended for all DC accesses.
- See application note AN0024 for details.

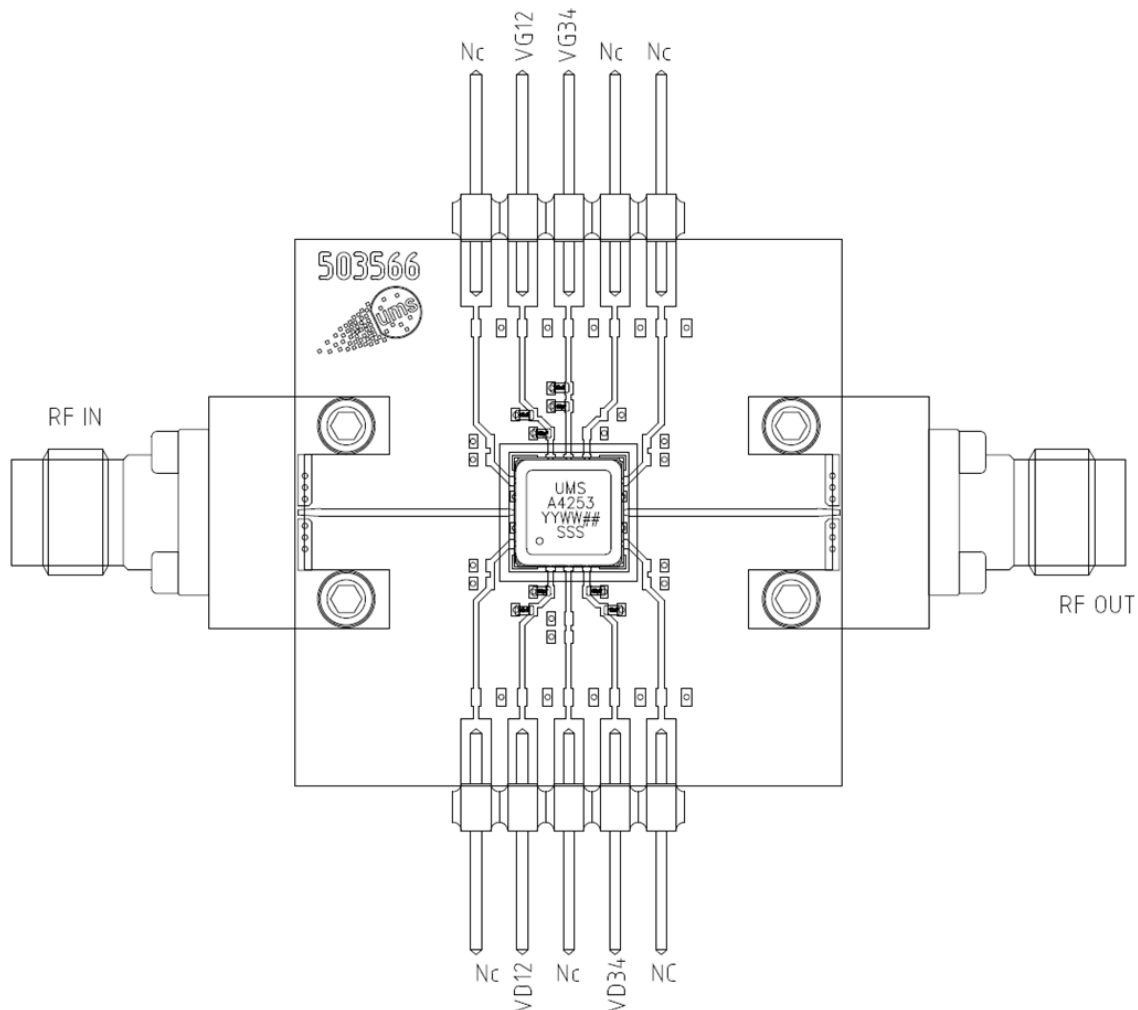

Note: All board measurements are performed using shielded cables, even for DC bias, to ensure safe operation.

### Definition of the Sij reference planes

The reference planes used for Sij measurements given above are symmetrical from the symmetrical axis of the package (see drawing beside). The input and output reference planes are located at 3.39mm offset (input wise and output wise respectively) from this axis. Then, the given Sij parameters incorporate the land pattern of the evaluation motherboard recommended in paragraph "Evaluation motherboard".

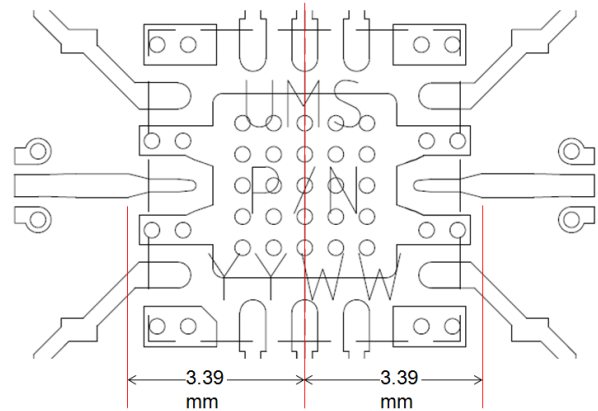

## DC Schematic

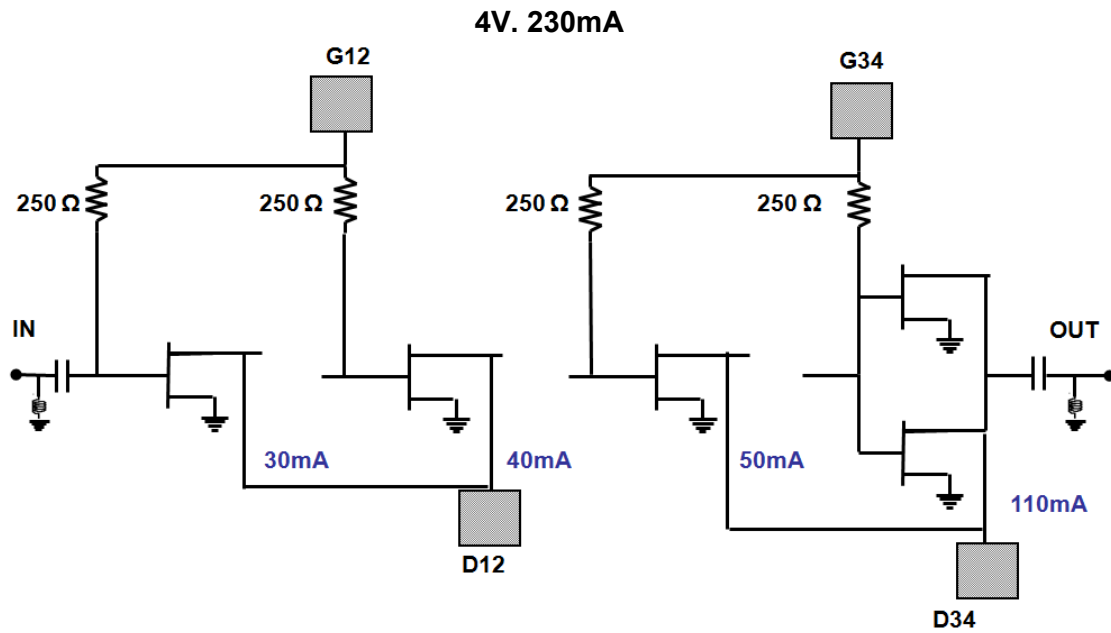

## Notes

Due to ESD protection circuits on RF input and output an external capacitance might be requested to isolate the product from external voltage that could be present on the RF accesses.

The DC connections do not include any decoupling capacitor in package. Therefore it is mandatory to provide a good external DC decoupling (100pF. 10nF) on the PC board as close as possible to the package.

## Recommended package footprint for FAB Package

Refer to the application note AN0024 available at <https://www.ums-rf.com> for package footprint recommendations and exact package dimensions.

## SMD mounting procedure for FAB Package

For the mounting process standard techniques involving solder paste and a suitable reflow process can be used. For further details see application note AN0024 available at <https://www.ums-rf.com>.

## Recommended environmental management

UMS products are compliant with the regulation in particular with the directives RoHS N°2011/65 and REACH N°1907/2006. More environmental data are available in the application note AN0019 also available at <https://www.ums-rf.com>.

## Recommended ESD management

Refer to the application note AN0020 available at <https://www.ums-rf.com> for ESD sensitivity and handling recommendations for the UMS package products.

## Ordering Information

Leadless hermetic package:

CHA4253-FAB/XY

Waffle pack: XY = 24

Information furnished is believed to be accurate and reliable. However **United Monolithic Semiconductors S.A.S.** assumes no responsibility for the consequences of use of such information nor for any infringement of patents or other rights of third parties which may result from its use. No license is granted by implication or otherwise under any patent or patent rights of **United Monolithic Semiconductors S.A.S.**. Specifications mentioned in this publication are subject to change without notice. This publication supersedes and replaces all information previously supplied. **United Monolithic Semiconductors S.A.S.** products are not authorised for use as critical components in life support devices or systems without express written approval from **United Monolithic Semiconductors S.A.S.**